



# QSZ13 CM2150

## Operation and Maintenance Manuals

C4365911

O20140528 version

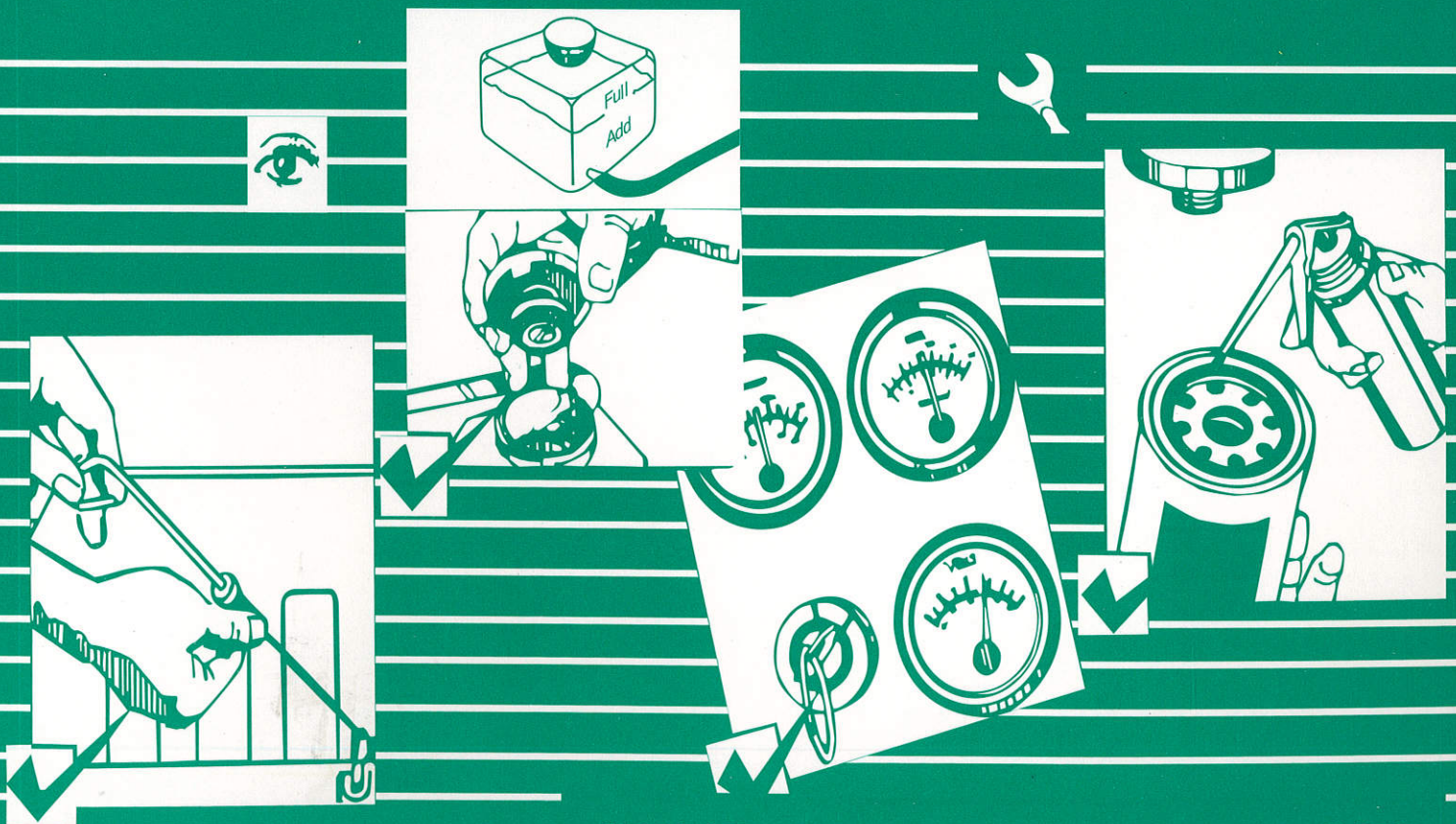

APPLIED TO NON PGBU QSZ ENGINES



# QSZ13 CM2150

## Operation and Maintenance Manuals

4365911

O20140528 version

(APPLIED TO NON PGBU QSZ ENGINES)

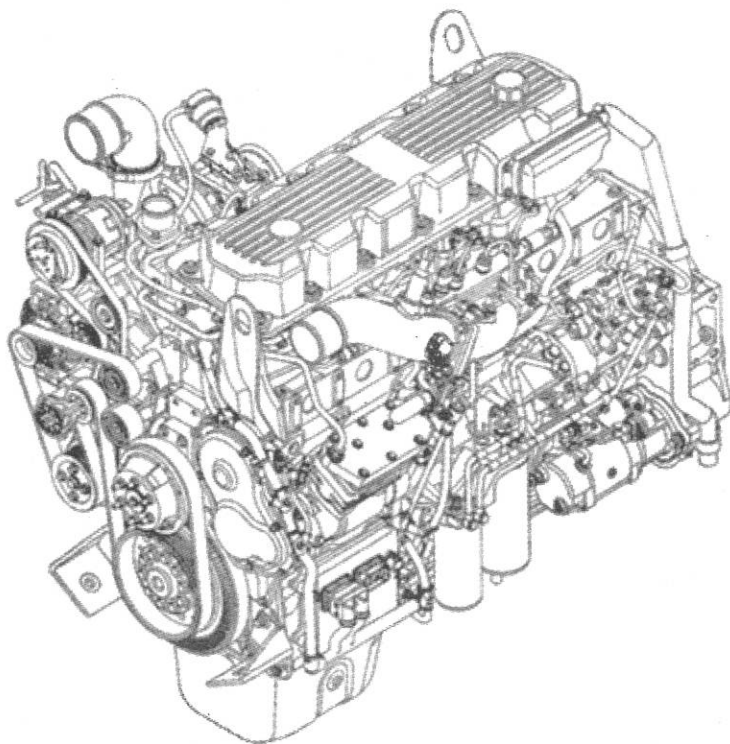

Dongfeng Cummins Engine Company, Ltd.

Marketing company

## Table of Contents

To the Owner and Operator .....	6
Important Safety Notice .....	7
General Repair Instructions .....	9
General Cleaning Instructions .....	11
Engine Identification .....	13
Engine Dataplate .....	13
ECM data plate .....	13
Engine Naming .....	14
Engine Diagrams .....	15
Specifications .....	20
General Engine Specifications .....	20
Engine Systems Specifications .....	20
Operation and Maintenance practices .....	24
Mandatory Maintenance Interval Chart.....	24
Basic Operation Requirements Chart.....	25
Operation Maintenance Guidance .....	28
1: Daily check content.....	28
2: The first maintenance 100 hours or 2 months maintenance content.....	34
3: Maintenance content for every 400 hours or 4 months.....	55
4: Maintenance content for every 800 hours or 8 months.....	76
5: Maintenance content for every 1,200 hours or 12 months .....	80
6: Maintenance content for every 2,000 hours or 20 months .....	81
7: Drain the antifreeze coolant every 2,400 hours or 24 months .....	84
Maintenance Assistance Guide .....	86

## Foreword

This manual contains correct operation and maintenance information about your engine, as well as the important safety information, engine and system specifications, fault diagnostic, troubleshooting guidelines and Dongfeng Cummins service support information. About the normal engine maintenance, please follow the requirements of "Quality Warranty Manual" to get support from the Dongfeng Cummins Authorized Service.

### **Read and follow all safety instructions.**

Keep this manual with the equipment. If the equipment is traded or sold, give the manual to the new owner.

The information, specifications, and recommended maintenance guidelines in this manual are based on information in effect at the time of printing. Dongfeng Cummins Engine Company, Ltd. reserves the right to change the information at any time without obligation. If you find differences between your engine and the information in this manual, please contact Customer Service Department of Dongfeng Cummins Engine Company, Ltd. Marketing Company. Contact number: 0710-3320168.

The latest technology and the highest quality components were used to produce this engine. When replacement parts are necessary, we recommend using only genuine Dongfeng Cummins parts.

**Enterprise standard No.: Q/DCEC3-2010**

**The National Industrial Production Permit No.:XK06-002-00411**



## To the Owner and Operator

Preventive maintenance is the easiest and least expensive type of maintenance. Please strictly follow the recommended maintenance schedules in "Maintenance Guide", and keep records of regular preventive maintenance

Choose the right fuel, oil and coolant according to Dongfeng Cummins regulation.

Dongfeng Cummins Engine Company uses the latest technology and the highest quality components to produce its engines. Cummins Inc. recommends using genuine Dongfeng Cummins parts

Early care service personnel at Dongfeng Cummins Authorized Repair Locations have been trained to provide expert service and parts support. If you meet problems that **can't** be resolved by Dongfeng Cummins Authorized Repair Location, please contact Infant Care engineers. Service hotline: 0710-3320168, 24-hour free service hotline 400-880-9119.

Product coverage, warranty limitations and owner responsibilities are available in "Quality Warranty Manual" of Dongfeng Cummins engines.



**Disconnect both the positive (+) and negative (-) battery cables from the battery before welding on the vehicle. Attach the welder ground cable no more than 0.61 meters [2 feet] from the part being welded. Do not connect the ground cable of the welder to the ECM cooling plate or ECM. Welding on the engine or engine mounted components is not recommended.**

## Important Safety Notice



**Improper practices, carelessness, or ignoring the warnings can cause burns, cuts, mutilation, asphyxiation, or other personal injury or death.**

Read and understand all of the safety precautions and warnings before performing any repair. This list contains the general safety precautions that **must** be followed to provide personal safety. Special safety precautions are included in the procedures when they apply.

- Work in an area surrounding the product that is dry, well lit, ventilated, free from clutter, loose tools, parts, ignition sources and hazardous substances. Be aware of hazardous conditions that can exist.
- **Always** wear protective glasses and protective shoes when working.
- Rotating parts can cause cuts, mutilation or strangulation.
- **Do not** wear loose-fitting or torn clothing. Remove all jewelry when working.
- Disconnect the battery (negative [-] cable first) and discharge any capacitors before beginning any repair work. Disconnect the air starter, if equipped, to prevent accidental starting. Put a "Do **Not** Operate" tag in the operator's compartment or on the controls.
- Use **ONLY** the proper engine barring techniques for manually rotating the engine. Do **not** attempt to rotate the crankshaft by pulling or prying on the fan. This practice can cause serious personal injury, property damage, or damage to the fan blade(s), causing premature fan failure.
- If an engine has been operating and the coolant is hot, allow the engine to cool before slowly loosening the filler cap to relieve the pressure from the cooling system.
- **Always** use blocks or proper stands to support the product before performing any service work. Do **not** work on anything that is supported **ONLY** by lifting jacks or a hoist.
- Relieve all pressure in the air, oil, fuel, and cooling systems before any lines, fittings, or related items are removed or disconnected. Be alert for possible pressure when disconnecting any device from a system that utilizes pressure. **Do not** check for pressure leaks with your hand. High pressure oil or fuel can cause personal injury.
- To reduce the possibility of suffocation and frostbite, wear protective clothing and **ONLY** disconnect liquid refrigerant (Freon) lines in a well ventilated area. To protect the environment, liquid refrigerant systems **must** be properly emptied and filled using equipment that prevents the release of refrigerant gas (fluorocarbons) into the atmosphere. Requires capturing and recycling refrigerant.
- to reduce the possibility of personal injury, use a hoist or get assistance when lifting components that weigh 23 kg [50 lb] or more. Make sure all lifting devices such as chains, hooks, or slings are in good condition and are of the correct capacity. Make sure hooks are positioned correctly. **Always** use a spreader bar when necessary. The lifting hooks **must not** be side-loaded.

- Corrosion inhibitor, a component of SCA and lubricating oil, contains alkali. **Do not** get the substance in your eyes. **Avoid prolonged** or repeated contact with skin. **Do not** swallow. In case of contact, immediately wash skin with soap and water. In case of contact, immediately flush eyes with large amounts of water for a minimum of 15 minutes. IMMEDIATELY CALL A PHYSICIAN. KEEP OUT OF REACH OF CHILDREN.
- NAPHTHA AND METHYL ETHYL KETONE (MEK) ARE FLAMMABLE MATERIALS AND **MUST BE USED WITH CAUTION**. Follow the manufacturer's instructions to provide complete safety when using these materials. KEEP OUT OF REACH OF CHILDREN.
- To reduce the possibility of burns, be alert for hot parts on products that have just been turned off, exhaust gas flow, and hot fluids in lines, tubes, and compartments.
- **Always** use tools that are in good condition. Make sure you understand how to use the tools before performing any service work. Uses the genuine Dongfeng Cummins parts only.
- **Always** use the same fastener part number (or equivalent) when replacing fasteners. **Do not** use a fastener of lesser quality if replacements are necessary.
- **Do not** perform any repair when fatigued or after consuming alcohol or drugs that can impair your functioning.
- Used engine oil can be carcinogenic and cause reproductive toxicity. Avoid inhalation of vapors, ingestion, and prolonged contact with used engine oil.
- **Do not** connect the jumper starting or battery charging cables to any ignition or governor control wiring. This can cause electrical damage to the ignition or governor.
- **Always** torque fasteners and fuel connections to the required specifications. Overtightening or under tightening can allow leakage.
- **Always** test for fuel leaks as instructed, as odorant can fade.
- Close the manual fuel valves prior to performing maintenance and repairs, and when storing the vehicle inside.
- Coolant is toxic. If **not** reused, dispose of in accordance with local environmental regulations.
- **DO NOT OPERATE A DIESEL ENGINE WHERE THERE ARE OR CAN BE COMBUSTIBLE VAPORS**. These vapors can be sucked through the air intake system and cause engine acceleration and over speeding that can result in a fire, an explosion, and extensive property damage. Numerous safety devices are available, such as air intake shutoff devices, to minimize the risk of overspeeding where an engine, due to its application, might operate in a combustible environment, such as due to a fuel spill or gas leak. Remember, DCEC has no way of knowing the use you have for your engine. The equipment owner and operator are responsible for safe operation in a hostile environment. Dongfeng Cummins recommends the installation of an air intake shutoff device or a similar safety device to minimize the risk of overspeeding when an engine is operating in a combustible environment, such as due to a fuel spill or gas leak.

## General Repair Instructions

This engine incorporates the latest technology at the time it was manufactured. Yet, it is designed to be repaired using normal repair practices performed to quality standards.

**DCEC does not recommend or authorize any modifications or repairs to engines or components except for those detailed in Cummins Service Information. In particular, unauthorized repair to safety-related components can cause personal injury or death. Below is a partial listing of components classified as safety-related from DCEC.**

1. AIR COMPRESSOR
2. Air Controls
3. Air Shutoff Assemblies
4. Balance weights
5. Cooling fan
6. Fan Hub Assembly
7. Fan Mounting Bracket(s)
8. Fan Mounting Capscrews
9. Fan Hub Shaft
10. flywheel
11. Flywheel Crankshaft Adapter
12. Flywheel mounting bolts
13. Fuel Shutoff Assemblies
14. Fuel Supply Tubes
15. Lifting brackets
16. Throttle Controls
17. Turbocharger Compressor Casing
18. turbocharger oil drain tube
19. Turbocharger oil supply line
20. turbocharger turbine housing
21. vibration damper mounting capscrews

- **Follow all safety instructions noted in the procedures**
- Follow the manufacturer's recommendations for cleaning solvents and other substances used during the repair of the engine. Some solvents and used engine oil have been identified by government agencies as toxic or carcinogenic. Avoid excessive breathing, ingestion and contact with such substances. Always use good safety practices with tools and equipment.
- Provide a clean environment and follow the cleaning instructions specified in the procedures
- The engine and its components must be kept clean during any repair. Contamination of the engine or components will cause premature wear.
- Perform the inspections specified in the procedures

- Replace all components or assemblies which are damaged or worn beyond the specifications
- Use the new genuine Dongfeng Cummins parts and assemblies
- The assembly instructions have been written to use again as many components and assemblies as possible. When it is necessary to replace a component or assembly, the procedure is based on the use of new Dongfeng Cummins components. All of the repair services described in this manual are available from all Dongfeng Cummins Distributors or most Dealer locations.
- Follow the specified disassembly and assembly procedures to reduce the possibility of damage to the components
- Shop Manuals contain complete shop specifications, which you can order or purchase from the Customer Service Department of Dongfeng Cummins Engine Company, Ltd. Marketing Company. Service hotline:0710-3320168.

## General Cleaning Instructions

### 1: Definition of clean

Parts **must** be free of debris that can contaminate any engine system. This does **not** necessarily mean they have to appear as new.

Sanding gasket surfaces until the factory machining marks are disturbed adds no value and is often harmful to forming a seal. It is important to maintain surface finish and the flatness tolerances to form a quality sealing surface. Gaskets are designed to fill small voids in the specified surface finish.

Sanding gasket surfaces where edge-molded gaskets are used is most often unnecessary. Edge-molded gaskets are those metal carriers with sealing material bonded to the edges of the gasket to seal while the metal portion forms a metal to metal joint for stability. Any of the small amounts of sealing material that can stick to the parts are better removed with a blunt-edged scraper on the spots rather than spending time polishing the whole surface with an air sander or disc.

For those gaskets that do **not** have the edge molding, nearly all have a material that contains release agents to prevent sticking. Certainly this is **not** to say that some gaskets are **not** difficult to remove because the gasket has been in place a long time, has been overheated or the purpose of the release agent has been defeated by the application of some sealant. The object however is just to remove the gasket without damaging the surfaces of the mating parts without contaminating the engine (don't let the little bits fall where they can not be removed).

Bead blasting piston crowns until the dark stain is removed is unnecessary. All that is required is to remove the carbon build-up above the top ring and in the ring grooves. There is more information on bead blasting and piston cleaning later in this document.

Dongfeng Cummins does not recommend polishing or grinding the carbon ring at the top of cylinder liners with abrasive paper until clean metal is visible. The liner will be ruined and any signs of a problem at the top ring reversal point (like a dust-out) will be destroyed. It is necessary to remove the carbon ring to provide for easier removal of the piston assembly. A medium bristle, high quality, steel wire wheel that is rated above the rpm of the power tool being used will be just as quick and there will be less damage. Yes, after removing the piston(s), search the broken steel wire carefully. But steel wire is easily visible, and it can be pulled out with magnet.

Oil on parts that have been removed from the engine will attract dirt in the air. The dirt will adhere to the oil. If possible, leave the old oil on the part until it is ready to be cleaned, inspected and installed, and then clean it off along with any attracted dirt. If the part is cleaned then left exposed it can have to be cleaned again before installation. Make sure parts are lubricated with clean oil before installation. They do **not** need to be oiled all over but do need oil between moving parts (or a good lube system priming process conducted before cranking the engine).

Bead blasting parts to remove exterior paint is also usually unnecessary. The part will most likely be painted again so all that needs happen is remove any loose paint.

## 2: Special tips for fuel system cleaning

When servicing any fuel system components, which can be exposed to potential contaminants, prior to disassembly, clean the fittings, mounting hardware, and the area around the component to be removed. If the surrounding areas are **not** cleaned, dirt or contaminants can be introduced into the fuel system.

The internal drillings of some injectors are extremely small and susceptible to plugging from contamination. Some fuel injection systems can operate at very high pressures. High pressure fuel can convert simple particles of dirt and rust into a highly abrasive contaminant that can damage the high pressure pumping components and fuel injectors.

Electrical contact cleaner can be used if steam cleaning tools are not available. Use electrical contact cleaner rather than compressed air, to wash dirt and debris away from fuel system fittings. Diesel fuel on exposed fuel system parts attracts airborne contaminants.

Choose lint free towels for fuel system work.

Cap and plug fuel lines, fittings, and ports whenever the fuel system is opened. Rust, dirt, and paint can enter the fuel system whenever a fuel line or other component is loosened or removed from the engine. In many instances, a good practice is to loosen a line or fitting to break the rust and paint loose, and then clean off the loosened material.

When removing fuel lines or fittings from a new or newly-painted engine, make sure to remove loose paint flakes/chips/ that can be created when a wrench contacts painted line nuts or fittings, or when quick disconnect fittings are removed.

Fuel filters are rated in microns. The word micron is the abbreviation for a micrometer, or one millionth of a meter. The micron rating is the size of the smallest particles that will be captured by the filter media. As a reference, a human hair is 0.003mm [3/1000 in] in diameter. The contaminants being filtered out are smaller than 0.00004mm can be seen with the human eye, a magnifying glass, or a low powered microscope.

The tools used for fuel system troubleshooting and repair are to be cleaned regularly to avoid contamination. Like fuel system parts, tools that are coated with oil or fuel attract airborne contaminants. Remember the following points regarding your fuel system tools:

- Fuel system tools are to be kept as clean as possible.
- Clean and dry the tools before returning them to the tool box.
- If possible, store fuel system tools in sealed containers.
- Make sure fuel system tools are clean before use.

# Engine Identification

## Engine Dataplate .

The engine dataplate, located on top of the rocker lever cover or on the side of gear cover, provides the model identification and other important data about the engine. Have the following engine data available when communicating with a Dongfeng Cummins Authorized Repair Location. The data on the dataplate are **boldmandatory/bold** when sourcing service parts:

1. Engine Type
2. Engine Serial Number (ESN)
3. Control Parts List (CPL)
4. Advertised horsepower and rpm
5. Shop order number (SO).

 <b>东风康明斯发动机有限公司</b> Dongfeng Cummins Engine Co., Ltd. 5303690 中国 湖北 襄阳 Xiangyang, Hubei, China	排量 Displacement	净质量 Net Weight	怠速 Idle Speed	型号 Model
	L	kg	r/min	发动机序列号 Engine Serial No.
注意:若用户超出本发动机所规定的供油量/转速/海拔高度运转,由此引起的损坏,不在保修范围之内。 Warning: Injury may result and warranty is voided if fuel rate rpm or altitudes exceed published maximum values for this model and application.	允许使用海拔高度限值 Altitude Limit	型式核准号 Approval No.	生产许可证 Licence No.	控制性零件表号 CPL
	m		额定供油率 Fuel rate at rated HP	额定功率/转速 Rated KW
限值阶段 Cert. Level	对应功率段 Power Range	KW	额定功率/转速 Rated KW	订单号 Shop Order
制造日期 Date of Mfg.			rpm	

## ECM data plate

THE ELECTRONIC CONTROL MODULE (ECM) DATAPLATE IS LOCATED ON THE FRONT OF THE ECM.

The abbreviations on the dataplate are explained as follow:

- P/N = Part Number
- S/N = Serial Number
- D/C = Date Code.

©Cummins Inc

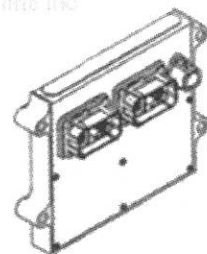

19804914

**NOTE:**THE PRESENCE OF AN ECM DATAPLATE DEPENDS ON THE MANUFACTURING PLANT AND THE DATE ON WHICH THE ENGINE WAS MANUFACTURED. IF AN ECM DATAPLATE WAS NOT INSTALLED BY THE MANUFACTURING PLANT, CALIBRATION DATA CAN BE FOUND ON THE ENGINE DATAPLATE.

## Engine Naming

The Cummins® engine nomenclature provides the engine model and horsepower rating.

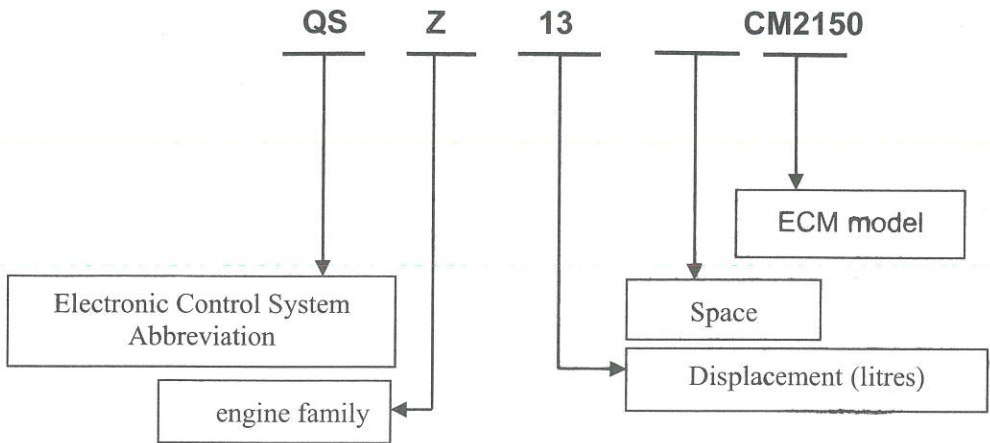

## Engine Diagrams .

The following illustrations show the location of the major external engine components, filters, and other service and maintenance points. Some external components will be different locations for different engine models.

Cummins Inc

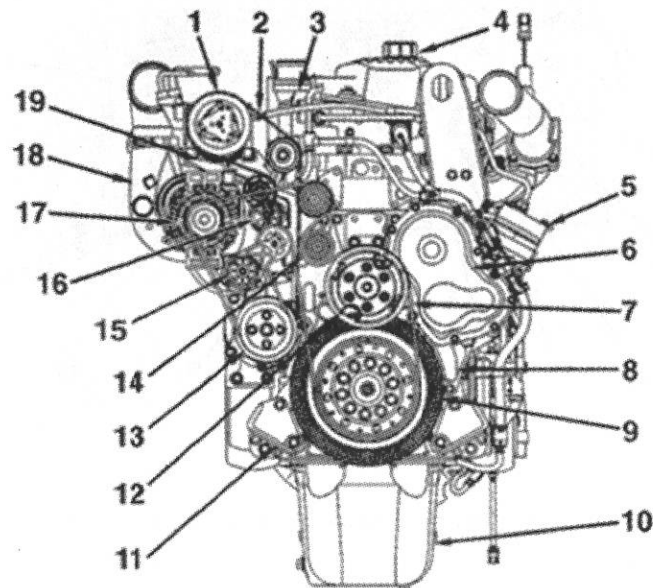

0000122

Front Engine View

- |   |  |
|---|--|
| 1. Refrigerant compressor               | 11. Front engine mounts                        |
| 2. Refrigerant compressor drive belt    | 12. Fan Pulley                                 |
| 3. Thermostat housing                   | 13. Water Pump                                 |
| 4. Lubricating Oil Fill Cover           | 14. Alternator idler pulley assembly           |
| 5. Air Compressors                      | 15. Belt tensioner, Alternator and water pump  |
| 6. Front gear cover                     | 16. Refrigerant compressor belt tension device |
| 7. Alternator and water pump belt drive | 17. Alternator                                 |
| 8. Oil fill cover                       | 18. Turbocharger                               |
| 9. Torsional vibration damper           | 19. Alternator Bracket                         |
| 10. Lubrication oil pan                 |  |

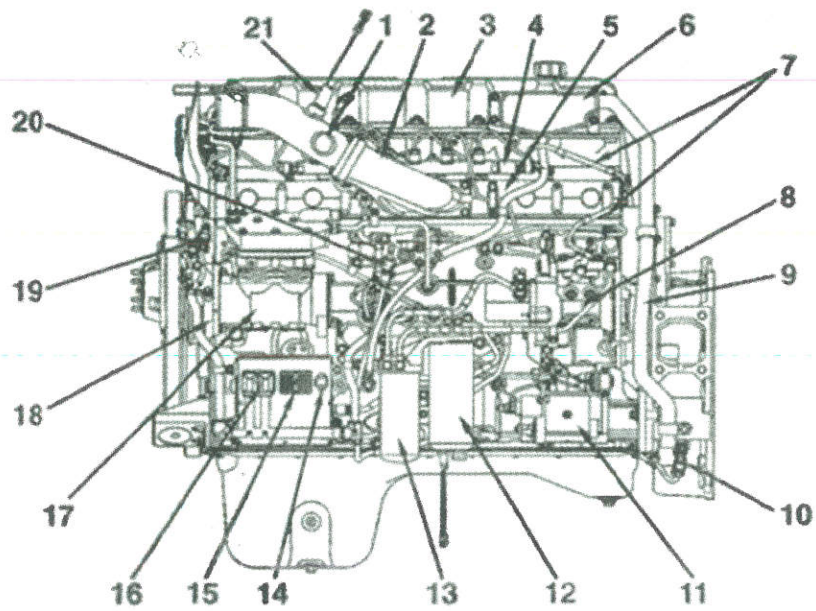

00:00:23

Left (Intake Side) Engine View

- |   |                                     |
|---|-------------------------------------|
| 1. Intake manifold connection (air intake connection) | 12. Fuel filter (fuel suction side) |
| 2. Air intake manifold                                | 13. Fuel filter (pressure side)     |
| 3. Rover lever cover                                  | 14. ECM Power Connections           |
| 4. Fuel rail pressure relief valve                    | 15. ECM OEM Harness Connector       |
| 5. Cylinder Head                                      | 16. ECM Engine Harness Connector    |
| 6. Crankcase Breather Housing                         | 17. Air Compressors                 |
| 7. Fuel Drain Lines                                   | 18. Front gear housing              |
| 8. high-pressure Fuel pump                            | 19. Camshaft Position Sensor        |
| 9. Crankcase breather vent tube                       | 20. Lubricating Oil Dipstick        |
| 10. Engine Speed Sensor (Flywheel)                    | 21. Turbocharger Control Valve      |
| 11. Starter   |                                     |

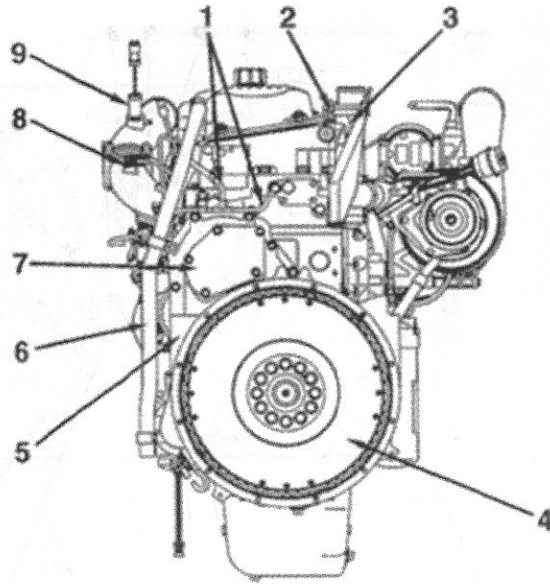

0000124

Rear Engine View

1. Fuel drain lines
2. Coolant temperature sensors
3. Thermostat housings
4. flywheel
5. flywheel housing
6. Crankcase breather vent tube
7. Rear gear cover plate
8. INAKE MANIFOLD PRESSURE/TEMPERATURE SENSOR
9. Turbocharger control valve.

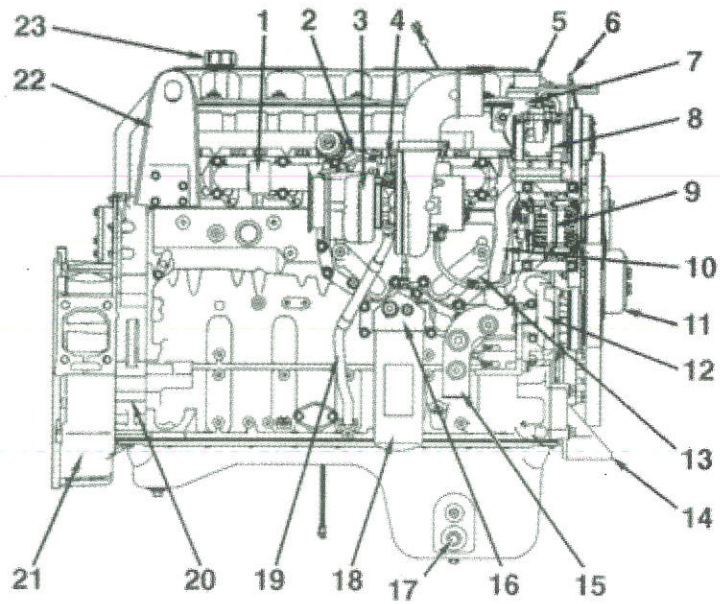

Right (Exhaust) Side Engine View

- |                                 |                                 |
|---------------------------------|---------------------------------|
| 1. Exhaust Manifold             | 13. Lubricating Oil Cooler      |
| 2. Wastegate                    | 14. Front engine mounts         |
| 3. Turbocharger                 | 15. Coolant inlet connection    |
| 4. Turbocharger Oil Supply Line | 16. Lubricating oil filter head |
| 5. Water outlet connection      | 17. oil drain plug              |
| 6. Engine Front Lift Bracket    | 18. Lubricating Oil Filter      |
| 7. Thermostat housing           | 19. Turbo Oil Drain Line        |
| 8. Refrigerant Compressor       | 20. rear gear housing           |
| 9. Alternator                   | 21. Flywheel Housing            |
| 10. Water transfer tube         | 22. Rear engine lifting bracket |
| 11. Fan Pulley                  | 23. Oil fill cover              |
| 12. Water pumps                 |                                 |

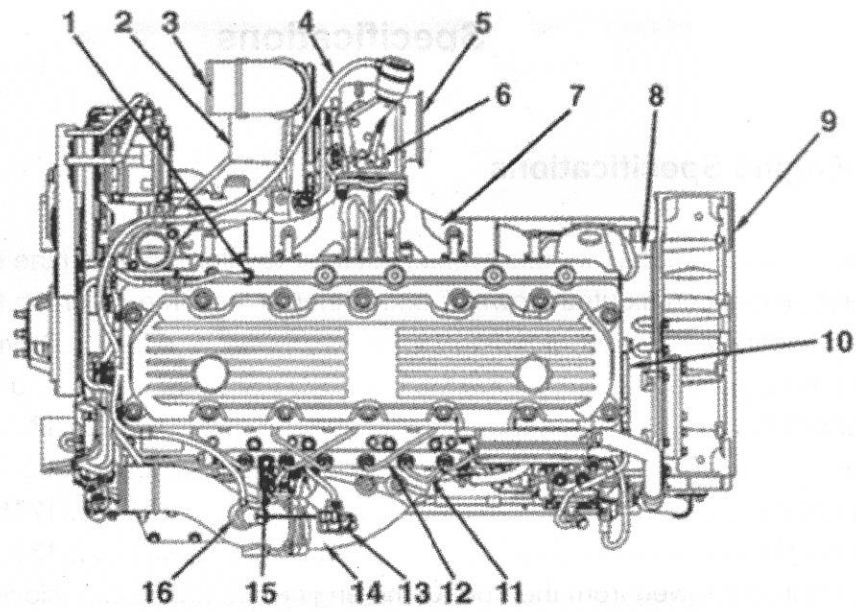

0000176

Top Engine View

- |   |   |
|---|---|
| 1. Coolant Temperature Sensor                   | 9. Flywheel Housing                             |
| 2. Turbocharger air inlet                       | 10. Fuel injector drain line                    |
| 3. Turbocharger compressed air outlet           | 11. Fuel rail supply tube                       |
| 4. Turbocharger wastegate valve air signal wire | 12. Injector supply lines                       |
| 5. Turbocharger Exhaust Outlet                  | 13. Intake Manifold Pressure/Temperature Sensor |
| 6. Turbocharger Wastegate Valve                 | 14. Air intake manifold                         |
| 7. Exhaust Manifold                             | 15. Fuel rail pressure sensor                   |
| 8. Rear gear housing                            | 16. Turbocharger Control Valve                  |

# Specifications

## General Engine Specifications

Horsepower.....	Refer to information on the engine dataplate
Engine speed at maximum output power.....	Refer to the information on the engine dataplate
Number of cylinders .....	6 cylinders
bore and stroke .....	130 mm x 163 mm
DISPLACEMENT .....	13 L
Firing order .....	1-5-3-6-2-4
dry engine weight.....	1245 kg
wet engine weight .....	1310 kg
Crankshaft rotation (viewed from the front of the engine).....	clockwise
intake valve lash .....	0.39mm
exhaust valve lash .....	0.72mm

## Engine Systems Specifications

### 1: Fuel system:

Maximum Fuel Supply Restriction (OEM end clean fuel filter).....	13.5 kPa
Maximum fuel drain restriction .....	.27 kPa

Maximum fuel drain tube pressure (load status).....	34 kPa
Maximum fuel inlet restriction at gear pump inlet (dirty filter, loaded condition).....	34 kPa
Maximum fuel inlet restriction at OEM connection (dirty filter, loaded condition).....	20 kPa

### Minimum Gear Pump Pressure

Cranking period.....	69 kPa
Rated power period.....	1000 kPa
Maximum delta pressure of filter .....	138 kPa
Minimum Engine Cranking Speed .....	80 rpm

### 2: Lubricating system:

#### Engine Oil Pressure:

Low Idle (minimum allowable).....	89.6 kPa
At 1200 rpm or Peak Torque (minimum allowable).....	207 kPa
full Lubricating Oil System capacity .....	45.42 L

### 3: Cooling system:

Coolant capacity (engine only).....	23.1 L
Standard thermostat modulating range.....	82 to 94°C
Max. coolant temp (engine outlet).....	102°C
Min. coolant temperature .....	71°C
Coolant alarm temperature .....	107°C
Maximum coolant pressure (without pressure cap, thermostats closed) .....	407 kPa
Allowable minimum pressure cap pressure .....	103 kPa
Maximum cooling system restriction .....	75 kPa
Maximum coolant expansion space (percentage to cooling system capacity) .....	10%
Minimum coolant expansion space (percentage to cooling system capacity) .....	6%
Minimum filling rate (low level warning most of the engines required).....	19 liters/minute
Maximum exhaust period.....	25 minute

### 4: Intake air system:

Recommended inside diameter of the engine intake manifold .....	200 mm
Recommended equivalent inside diameter of the aftercooling system.....	115 mm
Maximum intake air temperature rising between climate and turbocharger air inlet..	11.1 °C
Maximum intake air temperature rising between climate and intake manifold.....	30 °C
Maximum charge air cooling temperature that will not cause reduced engine performance (at sea level).....	60 °C
Charge air cooling alarm temperature (engine protection) .....	85 °C
Maximum intake restriction (Clean air filter element).....	3.2 kPa
Maximum intake restriction (dirty air filter element) .....	6.2 kPa
Maximum Aftercooling system restriction: .....	13 kPa
Maximum Allowable Pressure Drop From Turbocharger to Intake Manifold .....	13 kPa
Maximum Allowable Pressure Drop Across Charge-Air Cooler.....	10 kPa

### 5: Exhaust system

System allowable maximum exhaust restriction .....	13 kPa
Maximum stationary bending moments that the exhaust outlet flange surface can withstand .....	27 N.m
Minimum recommended exhaust pipe inside diameter.....	130 mm

### 6: Electrical System:

System voltage .....	24 V
Minimum recommended battery capacity of no lower than -18°C	
Cold cranking current:.....	900 CCA
Battery capacity:.....	270 min

### 7: Cold starting system:

Minimum cold starting temperature without starting aids.....	-15°C
Minimum cold starting temperature with starting aids (intake air warm-up).....	-30°C

**Additional:**

**Filter:**

Fleetguard® filters are standard on new Dongfeng Cummins Engines. Dongfeng Cummins recommends the use of them.

Fleetguard® products met all Cummins Company's Source Approval Test standards to provide the necessary filtration quality to achieve the engine's design life. If other brands are substituted, the purchaser **must** insist on products that the supplier has tested to meet Cummins high-quality standards.

Dongfeng Cummins Engine Company, Ltd. can **not** be responsible for problems caused by nongenuine filters that do **not** meet Cummins Inc. performance or durability requirements.

**FUEL**



Do not mix gasoline, alcohol, or gasohol with diesel fuel. This mixture can cause an explosion.

Due to the precise tolerances of diesel injection systems, it is extremely important that the fuel be kept clean and free of dirt or water. Dirt or water in the system can cause severe damage to both the fuel pump and the fuel injectors.

Dongfeng Cummins recommends the use of the fuel with emission legislation compliance. Using diesel meeting emission legislation can achieve the best engine performance and emission requirements.

**Lubricating oil**

**Recommend Oil Viscosity and Class Use Table**

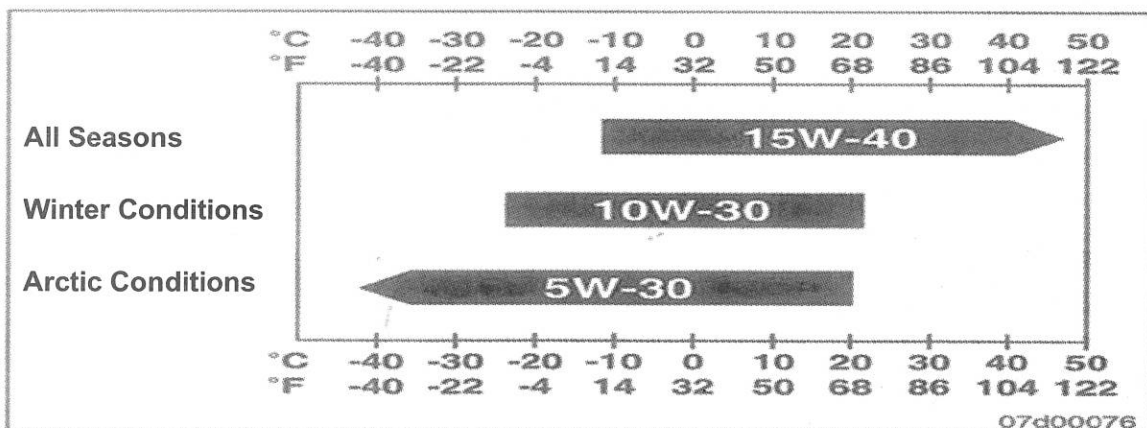

Two technical indicators should be focused on during oil selection: 1. oil class, 2. oil viscosity grade.

Select engine oil class on the basis of the engine models listed on the "Recommend Oil Viscosity and Class Use Table", and select oil viscosity grade on the basis of "Recommend Oil Viscosity and Class Use Table" and environment temperature range. Oil only satisfying the oil class and viscosity grade requirements can be used for the corresponding engine.

Dongfeng cummins qsz13 cm2150 engine must use ch and above high quality heavy-duty oil. REFER TO THE ENGINE OPERATION ENVIRONMENT TEMPERATURE FOR SELECTING THE VISCOSITY GRADE, AND IN MOST OF CHINA SAE15W-40CAN BE USED.

Principle of the engine oil storage: avoid pollution; stay dry and ventilated to avoid deterioration of oil quality due to too low or too high environment temperature; label must be correct and clear.

Oil normal storage: indoor dry and ventilated place, where the maximum environment temperature does not exceed 66°C, and the minimum does not lower than 4°C; indoor humidity between 50% to 70%. Storage time of the engine oil as follows:

No unsealing	Shelf life
Mineral spirits	3 years
Synthetic oils	5 years
After breaking the seal, seal second time	Shelf life
Mineral spirits, synthetic oils	18 months

### The coolant

Coolant must be genuine Dongfeng Cummins long life organic coolant.

- Do not substitute water for coolant; when lack of coolant, it is not allowed to add the normal hard water to an engine, such as well water, river water and tap water.
- It is forbidden to fill the mixture of different types of coolants to engine, otherwise it will cause serious consequence;
- Not in accordance with the requirements for correct operation, it will cause the malfunction or damage to the engine cooling system, which Dongfeng Cummins will not undertake any responsibilities.

Coolant storage principle: in cool and ventilated place; avoid direct sunlight; tighten the cover after operation to avoid contact with air oxidation, thus impact the performance.

The normal storage of coolant: Minimum temperature depends on the freezing point (generally NO. 45 corresponds to -7 °C), and the highest temperature does not exceed 55 °C. The coolant storage time is shown as follows:

Coolant type	Storage period
Inorganic	No more than two years
Organic	No more than five years

# Operation and Maintenance practices

## Mandatory Maintenance Interval Chart

	Daily Check	New engine inspection 30-50 hours	First maintenance regulation					
			100 hours 2 months Maintenance content	400 hours 4 months Maintenance content	800 hours 8 months Maintenance content	1,200 hours 12 months Maintenance content	1600 hours 16 months Maintenance content	2000 Hours 20 months Maintenance content
Replacement items			Change Engine Oil	Change Engine Oil	Change Engine Oil	Change Engine Oil	Change Engine Oil	Change Engine Oil
			Change lubrication oil filter	Change lubrication oil filter	Change lubrication oil filter	Change lubrication oil filter	Change lubrication oil filter	Change lubrication oil filter
			Change Fuel Filters	Change Fuel Filters	Change Fuel Filters	Change Fuel Filters	Change Fuel Filters	Change Fuel Filters
				Replace the steering hydraulic oil	Replace the steering hydraulic oil	Replace the steering hydraulic oil	Replace the steering hydraulic oil	Replace the steering hydraulic oil
						Replace the aftertreatment oil separator (if equipped)		Replace the filter element of the Diesel Exhaust Fluid tank (if equipped)
						Replace thermostats		Replace the aftertreatment doser pump primary element (if equipped)
Check the washing items	Lubricants Level	For inspection content see New Engine Inspection Card	Inspect the air cleaner	Inspect the air cleaner	Inspect the air cleaner	Inspect the air cleaner	Inspect the air cleaner	Inspect the air cleaner
	The Coolant Surface		Check the air intake system	Check the air intake system	Check the air intake system	Check the air intake system	Check the air intake system	Check the air intake system
	Drive Belt and Fan		Check the Aftercooler	Check the aftercooler	Check the aftercooler	Check the aftercooler	Check the aftercooler	Check the aftercooler
	Drain of Fuel-Water Separators				Aftertreatment system flush (if equipped)		Aftertreatment system flush (if equipped)	Check radiator hoses
	Check if there is a leakage on lockbolts, nuts and braking system (if equipped) of the air compressor				Check the fan shaft bearings and bolts		Check the fan shaft bearings and bolts	Check the air compressor discharge lines
	Air inlet pipe				Check the belt pulley and belt tension		Check the belt pulley and belt tension	Check the vibration damper
	Crankcase vent tube							Engine Steam Clean - Clean
	Air Tank and Reservoirs (if equipped)		Check the battery, battery cables and connections	Check the battery, battery cables and connections	Check the battery, battery cables and connections	Check the battery, battery cables and connections	Check the battery, battery cables and connections	Check the battery, battery cables and connections
	Check the urea level (if equipped)				Check and tighten the cylinder head bolts		Check and tighten the cylinder head bolts	
			Valve Clearances	Valve Clearances	Valve Clearances	Valve Clearances	Valve Clearances	Valve Clearances

		Engine brake clearance	Engine brake clearance	Engine brake clearance	Engine brake clearance	Engine brake clearance	Engine brake clearance
--	--	------------------------	------------------------	------------------------	------------------------	------------------------	------------------------

• **Notes:**

(1) ENGINE OIL MUST BE DONGFENG CUMMINS GENUINE CH GRADE OR ABOVE;

(2) Coolant must be genuine Dongfeng Cummins long life organic coolant;

(3) After 2000-hour item completes, circulate according to contents in items of every other 400 hours, 800 hours, 1,200 hours and 2,000 hours, whichever hours and months occur first, until Quality Warranty Period ends. We hope customers can maintain their engines referring to this content even after Quality Warranty Period ends.

(4) The manual provides maintenance instructions. Refer to Quality Warranty Manual for Warranty regulation.

### Basic Operation Requirements Chart

Before engine start	<p>Inspect the intake air system, fuel system, lubricating system, cooling system, and relevant electric circuit, Whether the aftertreatment system and fault alarm lamp is lit, and search:</p> <ul style="list-style-type: none"> <li>● Leak point</li> <li>● Loose position and damaged parts</li> <li>● Any change in engine appearance</li> </ul>
Start the engine	<ul style="list-style-type: none"> <li>● The operating lever of the hydraulic system or transmission should position in neutral.</li> <li>● Do not step on accelerator.</li> <li>● Turn the keyswitch to "ON" position, wait until "WAIT-TO-START" indicator light turns off, then start the engine.</li> <li>● Motor start time cannot exceed 30 seconds, and the interval between two starts should be 2 minutes.</li> <li>● If the fault codes currently exist, solve the problems before start the engine.</li> <li>● If the engine start cannot succeed in 3 times attempt, inspect the electric control system and fuel system.</li> <li>● If there is no oil pressure in 15 seconds after engine start, shut down the engine immediately, and check the lubrication system.</li> </ul>

<p>First start after draining the oil or long term shutdown (more than 30 days).</p>	<ul style="list-style-type: none"> <li>● Rotate the engine with relevant tool</li> <li>● Rotate the crankshaft with the starter motor (every starting time is no more than 30 seconds, intervals no less than 2 minutes) until pressure appears on the gauge or the warning light goes out.</li> </ul>
<p>After engine start</p>	<ul style="list-style-type: none"> <li>● Load after at least 3 - 5 minutes idle operation to insure the normal lubrication.</li> <li>● It is not allowed to make the engine operate at idle more than 10 minutes.</li> <li>● Do not keep the engine throttle fully open for more than 30 seconds below engine speed of peak torque (refer to dataplate of the given peak torque speed), otherwise it will shorten the engine life, and lead to serious damage to the engine;</li> <li>● Do not operate the engine beyond maximum speed of the engine, otherwise it will lead to serious engine damage;</li> <li>● Continuous operation with engine coolant temperature above or below the engine coolant temperature specifications listed in Maintenance Specifications can damage the engine.</li> </ul>
<p>The engine requires to repair if the engine has the following conditions:</p>	<p>Misfire, vibration, abnormal noise, leakage, water temperature and oil pressure changes suddenly, smoking, power reduction, oil lack of pressure and fuel consumption increase.</p>
<p>After engine full load operation</p>	<ul style="list-style-type: none"> <li>● Shut off the engine after 3-5 minutes' idle operation;</li> <li>● When engine flameout, stay in "ON" position for at least 30 seconds, then cut off the power supply.</li> <li>● Do not flush the engine with water.</li> </ul>
<p>Read Fault Codes</p>	<p>(1) Faults reading mode of faults indicator light (Flash Code):</p> <ul style="list-style-type: none"> <li>● Turn the keyswitch to OFF position, and turn the diagnostic switch to ON position.</li> <li>● Turn the vehicle keyswitch to ON position (engine yellow indicator light and red indicator light). If no active fault codes are recorded, both lights will come on and stay ON. If active fault codes are recorded, both lights will come on momentarily then begin to flash the code of the recorded faults.</li> <li>● The fault code will flash in the following sequence. First, a WARNING (amber) light will flash. THEN THERE WILL BE A SHORT 1 OR 2 SECOND PAUSE AFTER WHICH THE NUMBER OF THE RECORDED FAULT CODE WILL FLASH IN (RED) STOP.</li> </ul>

	<p>There is a one- or two-second pause between each number. When the number has finished flashing in red, an amber light will appear again.</p> <ul style="list-style-type: none"><li>● The lights flash each fault code out three times before advancing to the next code. To skip to the next fault code, move the Increment/Decrement switch (if equipped) momentarily to the increment (+) position. You can go back to the previous fault code by momentarily moving the Increment/Decrement switch, if equipped, to the decrement (-) position. If only one active fault is recorded, the same fault code will continuously be displayed when either (+) or (-) switch is depressed.</li><li>● When not using the diagnostic system, turn off the diagnostic switch.</li></ul> <p>(2) LCD fault reading mode: If an OEM vehicle equips Liquid Crystal Display, it will directly load on the LCD.</p>
--	--

# Operation Maintenance Guidance

## 1: Daily check content

**Overview:** Good preventative maintenance begins with day-to-day awareness of the engine and its system. Before starting the engine, check the oil and coolant levels. Look for:

- leaks
- Loose or damaged parts
- Worn or damaged belts
- Any change in engine appearance.
- Odor of fuel
- Odor of electronic devices

### Unusual Engine Noise

During the daily maintenance check, listen for any unusual engine noise, which can indicate that service is required.

### Engine monitoring for daily operation

The engine **Must** be maintained in top mechanical condition if the operator is to get optimum satisfaction from its use. The maintenance department needs daily running reports from the operator to make necessary adjustments in the time allocated. The daily running report also helps to make provisions for more extensive maintenance work as the reports indicate the necessity.

Comparison and intelligent interpretation of the daily report along with a practical follow-up action will eliminate most malfunctions and emergency repairs.

Report to the maintenance department any of the following conditions that may apply:

- Lubricating Oil Pressure Low in
- Low Power
- Power increases or engine surge
- Erratic or no accelerator control or response
- Any warning lights flashing or staying on
- Abnormal water or oil temperature
- Unusual System Noise
- Excessive smoke
- Excessive use of coolant, fuel, or lubricating oil
- Any fuel, coolant, or lubricating oil leaks
- Loose or damaged parts
- Worn or damaged belts
- Worn or damaged low or high voltage harnesses

## Air inlet pipe

Visual check intake piping daily for wear points, damage to piping, pipe clamp loosening or broken that may damage the engine. Replace damaged pipes and tighten loose clamps as necessary, to prevent the air system from leaking.

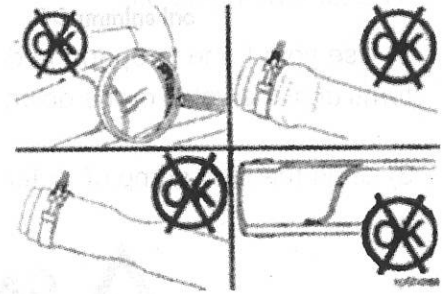

**Torque = 8 N.m[72 in-lb]**

Check for corrosion under the clamps and hoses of the intake system piping. Corrosion can allow corrosive products and dirt to enter the intake system. Disassemble and clean, as required as required.

## Crankcase breather tube

Inspect the breather tube for sludge, debris, or ice in the tube. Inspect the tube more frequently in icy conditions. If sludge, debris or freeze is found, clean the tube with detergent, warm water or solvent. Dry the tube with compressed air. Visual check the tube for cracks or damage. Replace the crankcase breather tube if any damage is found. Contact a DCEC Authorized Repair Location.

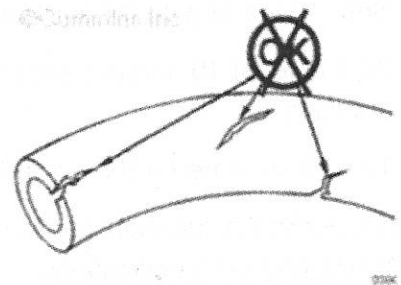
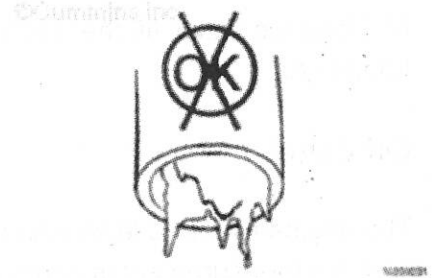

## Fuel-water separator



**WARNING**

Drain the water-fuel separator into a container and dispose of in accordance with local environmental regulations.

DCEC requires a fuel-water separator or fuel filter be installed in the fuel supply system.

Drain the water and sediment from the separator daily.

### Operating procedure:

- 1) Shut the engine off.
- 2) Use your hand to open the drain valve. **turn the valve counterclockwise** approximately 3 ½ turns until the valve drops down 25.4 mm and draining occurs.
- 3) Drain the filter sump of water until clear fuel is visible.



When closing the drain valve, do not over tighten the valve. Over tightening can damage the threads.

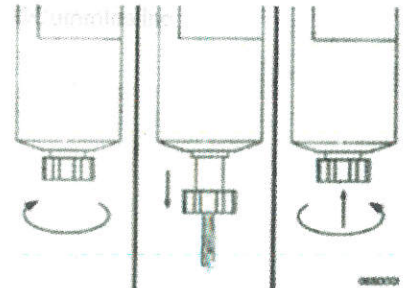

- 4) Close the valve, lift the valve and turn **clockwise** until it is hand-tight.

### Oil Level

The engine **must** be level when checking the oil level to make sure the measurement is correct.

Shut off the engine for an accurate reading.

Wait at least 15 minutes after shutting off the engine to check the oil level.

This allows time for the oil to drain to the oil pan.

For additional lubricating oil recommendations and oil pan capacity information, refer to Maintenance Specifications.

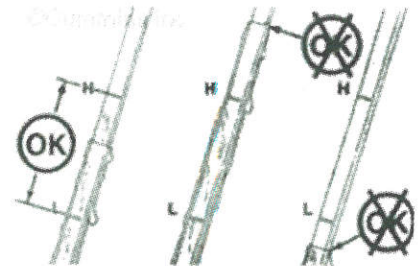

### Cooling fan

Inspect for reuse.



Do not rotate the engine by pulling or prying on the fan. The fan blade(s) can be damaged and cause the fan to fail and cause personal injury or property damage. Use the accessory drive shaft or the crankshaft barring tool to rotate the crankshaft.

A visual inspection of the cooling fan is required daily. Inspect for cracks, loose rivets, and bent or loose fan blades. Check the fan to make sure it is securely mounted. Tighten the bolts if necessary.

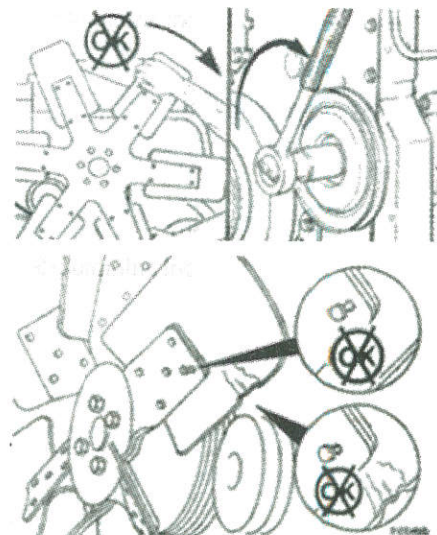

## ⚠ WARNING ⚠

Do not straighten a bent fan blade or continue to use a damaged fan. A bent or damaged fan blade can fail during operation, causing serious personal injury or property damage.

Replace any original equipment fan that is damaged with a fan of the identical part number.

DCEC **must** approve any other fan changes to be covered under warranty.

Refer to the vehicle or equipment manufacturer's specifications for capscrew torque.

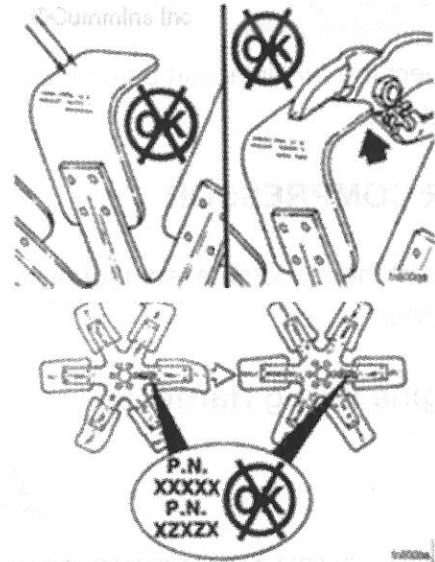

## COOLANT LEVEL

### ⚠ WARNING ⚠

Do not remove the pressure cap from a hot engine. Wait until the coolant temperature is below 50°C before removing the pressure cap. Or hot coolant spray or steam can cause personal injury.

The coolant level must be checked daily.

Coolant must be genuine Dongfeng Cummins long life organic coolant.

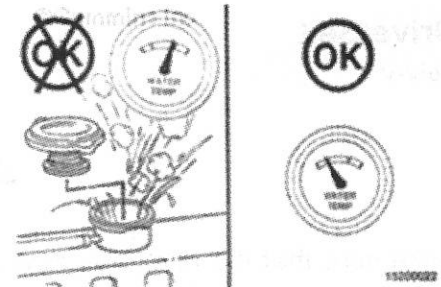

## ⚠ CAUTION ⚠

Do not add cold coolant to a hot engine. Engine castings can be damaged. Allow the engine to cool to below 50°C before adding coolant.

Fill the cooling system with coolant to the bottom of the fill neck in the radiator fill or expansion tank.

**Notes:** Some radiators have two fill necks, both of which must be filled when the cooling system is drained.

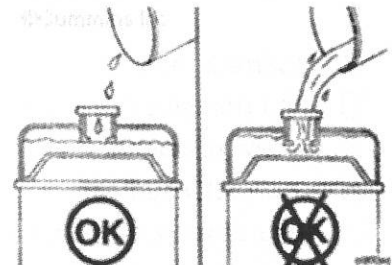

## Fuel pumps

Inspect the fuel injection pump mounting nuts, including the support bracket, for loose or damaged hardware.

## AIR COMPRESSOR

Inspect the air compressor mounting nuts, including the tail support bracket, for loose or damaged hardware.

## Engine Wirng Harness



**NEVER TOUCH ANY WIRING CONNECTION WHEN THE KEYSWITCH IS IN THE ON POSITION.** An electrical shock or personal injury can result.

Inspect all wiring connections and wiring harnesses for damage. Faulty wiring can cause improper engine operation and poor performance.

## Drive Belt

Poly-V



Make sure that the engine is **switched off** and any starting mechanisms are isolated before any inspections are made. Daily belt inspections can be carried out through an appropriate aperture. **Do not** remove any guards.

Inspect the belts daily. Check belt for intersecting cracks. Traverse (across the belt width) cracks are acceptable. Longitudinal (direction of belt ribs) cracks that intersect with transverse cracks are **not** acceptable. Replace the belt if it is frayed or has chunks of material missing.

Belt damage can be caused by:

- incorrect tension
- Incorrect size or length
- pulley misalignment
- incorrect installation
- severe operating environment
- Oil or grease on the side of the belts.

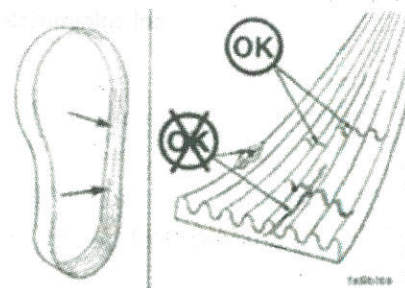

## Cogged Belt

Inspect the belts daily. Replace the belt if it has unacceptable cracks, is frayed, or has pieces of material missing. Small cracks are acceptable.

Adjust the belts that have a glazed or shiny surface, which indicates belt slippage. Correctly installed and tightened belts will show even pulley and belt wear.

Belt damage can be caused by:

- incorrect tension
- Incorrect size or length
- pulley misalignment
- incorrect installation
- severe operating environment
- Oil and grease on the belts.

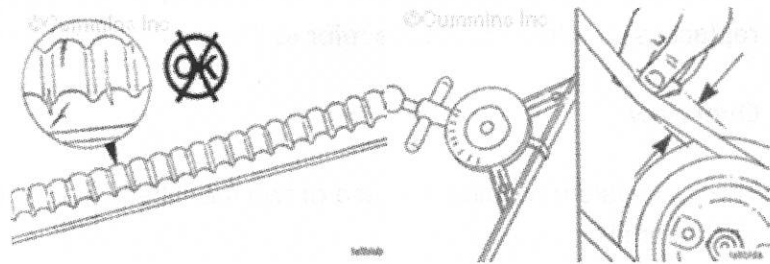

## 2: The first maintenance 100 hours or 2 months maintenance content

Overview: All maintenance checks and inspections listed in previous maintenance intervals **must** also be performed at this time, in addition to those listed under this maintenance interval.

### Fuel filter(s)

Fuel filter must be replaced every 100hours or 2 months operation. For other specified replacement intervals, please refer to the Maintenance Intervals Charts.

#### Overview

The fuel system requires the use of two fuel filters. The suction side filter **must** have the following characteristics:

- Water-separating
- 7-micron rating
- Water-in-fuel sensor with shunt resistor
- Water-drain valve.
- Engine mounted.

The pressure-side filters **must** have the following characteristics:

- 3-micron rating
- Engine mounted.

#### Preparatory

### WARNING

Batteries can emit explosive gases. To reduce the possibility of personal injury, always ventilate the compartment before servicing the batteries. To reduce the possibility of arcing, remove the negative (-) battery cable first and attach the negative (-) battery cable last.

Wear appropriate eye and face protection when using compressed air. Flying debris and dirt can cause personal injury.

### WARNING

When using steam, wear safety glasses or a face shield, as well as protective clothing. Hot steam can cause serious personal injury.

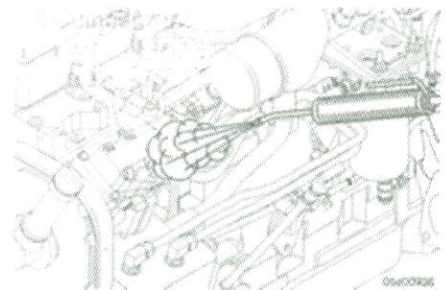

## ▲ CAUTION ▲

Clean all fittings before disassembly. Dirt or contaminants can damage the fuel system.

Before servicing **any** fuel system components, (such as fuel lines, fuel pump, injectors, etc.) which would expose the fuel system or internal engine component to potential contaminants prior to disassembly, clean the fittings, mounting hardware, and the area around the component to be removed. If the surrounding areas are **not** cleaned, dirt or contaminants can be introduced into the fuel system and engine, resulting in damage to the fuel system and engine.

Clean fuel filter head adapter, connector and mating components with contact cleaner, Part Number 3824510 or equivalent.

- Disconnect battery. Refer to the OEM repair instructions.
- Steam clean the engine.

### REMOVE

## ▲ WARNING ▲

Depending on the circumstance, diesel fuel is flammable. When inspecting or performing service or repairs on the fuel system, to reduce the possibility of fire and resulting in severe personal injury, death, or property damage, never smoke or allow sparks or flames (such as pilot lights, electrical switches, or welding equipment) in the work area.

Remove the fuel filter with filter wrench, Part Number 3400157.

Be sure the seal ring does **not** stick to the filter head.

Remove the seal ring with an o-ring pick, if necessary.

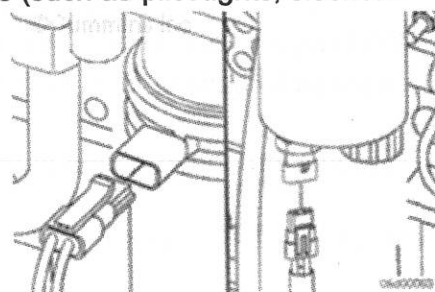

### Mount

Use the correct filter(s) for the engine. It must remove a minimum of 98.7 percent of free and emulsified water. It must also reach the removal efficiency for 3-micron particle.

Apply a thin coating of clean engine oil to the filter gasket surface and the center seal.

©Cummins Inc

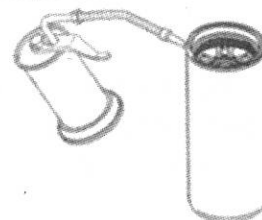

**NOTE: Dongfeng Cummins ®/Fleetguard® filter is equipped with disposable filter elements, which can prevent fuel from entering the clean side of the filter media when in pre-injection.**

06C0216

## ▲ CAUTION ▲

Mechanical overtightening of the filter can distort the threads and damage the fuel filter seal.

**NOTE: Engines equipped with priming pumps do not require the fuel filter to be filled prior to installation if the following filling procedure is followed.**

Install the filter onto the filter head.

Turn the filter until the gasket contacts the filter head surface.

Tighten the filter an additional 3/4 of a turn after the gasket contacts the filter head surface, or as specified by the manufacturer.

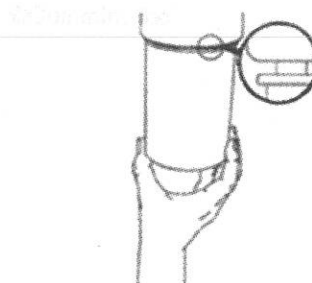

07200708

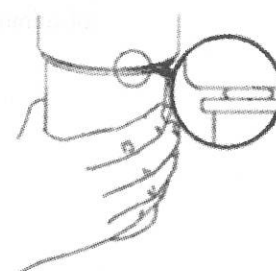

07200046

### Finishing Step

## ▲ WARNING ▲

Batteries can emit explosive gases. To reduce the possibility of personal injury, always ventilate the compartment before servicing the batteries. To reduce the possibility of arcing, remove the negative (-) battery cable first and attach the negative (-) battery cable last

Connect the battery. Refer to the OEM repair instructions.

Prime the fuel system.

Operate the engine and inspect for leaks.

### Lubricating Oil & Filters

## ▲ WARNING ▲

Used engine oil can be carcinogenic and cause reproductive toxicity. Avoid inhalation vapors, ingestion, and prolonged contact with used engine oil. If not reused, dispose of in accordance with local environmental regulations.

## ▲ WARNING ▲

To reduce the possibility of personal injury, avoid direct contact of hot oil with the skin.

**Engine oil and oil filter must be replaced every 100 hours or 2 months operation.**

Operate the engine until the water temperature reaches 60°C [140°F]. Shut the engine off.

Remove the oil drain plug from the bottom of the oil pan to completely drain oil.

Clean the area around the lubricating oil filter head.

Use oil filter wrench to remove the oil filter(s).

Clean the gasket surface on the lubricating oil filter head. **THE O-RING CAN stick on the filter head; make sure it is removed.**

**Fill.**

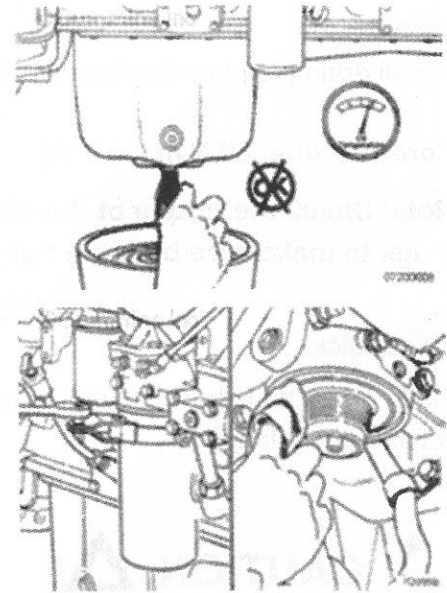

## ⚠ CAUTION ⚠

**Never replace a lubricating filter with any other lubricating filter without verifying adequate clearance with suspension and/or chassis at extremes of travel. Damage to the engine can occur.**

Use the correct oil filter for the engine.

Dongfeng cummins engine company requires the use of a lubricating oil filter that meets DCEC® source approved method (sam) 10,765.

## ⚠ CAUTION ⚠

**Lack of lubrication due to no oil in the oil filter leads to severe engine harm.**

## ⚠ CAUTION ⚠

**Mechanical overtightening of the lubricating oil filter can distort the threads or damage the lubricating oil filter seal.**

Fill the filter with clean oil. Choose the correct oil with correct amount for your operating climate.

Apply a light film of clean oil to the gasket sealing surface before installing the new filter.

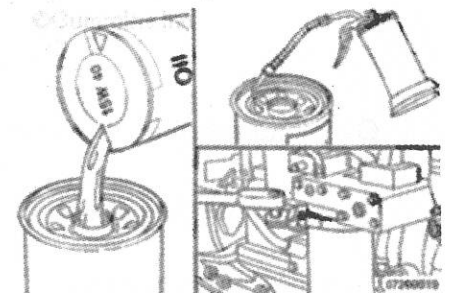

Install the filter on the filter head. Tighten until the gasket contacts the filter head surface.

Use oil filter wrench, Part Number 3400157, to tighten the filter to the specifications supplied with the filter.

Clean and check the oil drain plug threads and the seal surface.

Install drain plug from both sides of sump for oil pan.

**Torque Value:** 80 N.m [59 ft-lb]

**Note: Check the torque of the side and bottom oil drain plugs to make sure both are tight.**

Fill the engine with clean lubricating oil to the h (high) mark on the dipstick.

Mark. Take the following steps to confirm the total system volume (including filter).

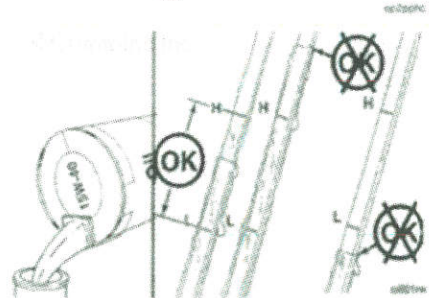
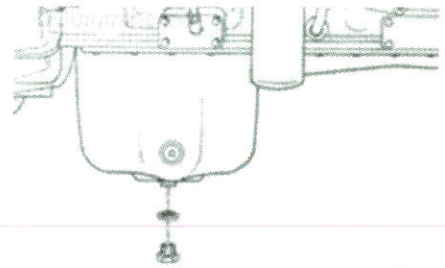

## ⚠ CAUTION ⚠

Engine oil pressure must be indicated on the gauge within 15 seconds after starting. If the oil pressure is not registered within 15 seconds, shut off the engine immediately to prevent engine damage. Confirm the correct oil level in the oil pan.

Operate the engine at idle speed to inspect for leaks at the filter (s) and the drain plug.

Shut off engine. Wait approximately 10 minutes to let the lubricating oil from the upper parts of the engine drain back into the lubricating oil pan.

Check the lubricating oil level again. As necessary, Add oil to the H (high) mark on the dipstick.

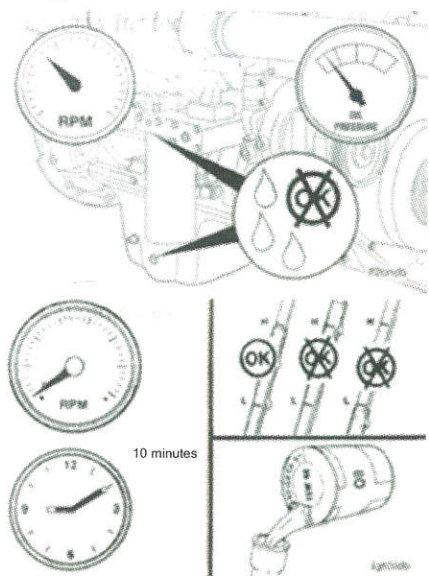

## COOLANTS

## ⚠ CAUTION ⚠

Overconcentration of coolant or use of high silicate coolant can damage the engine.

Coolant **must** be genuine Dongfeng Cummins long life organic coolant.

Antifreeze is essential in all climates.

Antifreeze broadens the operating temperature range by lowering the coolant freezing point and by raising its boiling point.

The coolant drain interval usually is 2,400 hours or 24 months (if the coolant quantity is enough and no leaks).

## **Air filter**



Holes, loose-end seals, dented sealing surfaces, corrosion of pipes, and other forms of damage render the cleaner inoperative and require immediate element replacement.

### **Remove:**

1. Before disassembly, wipe dirt from the cover and the upper portion of the air cleaner.
2. Loosen the wing bolt(s), and remove the band clamp securing the dust pan.
3. Remove the dust shield from the dust pan.
4. Clean the dust pan and dust shield.
5. Remove the wing nut(s) that secures the air filter primary element in the air filter housing.
6. Inspect the rubber sealing washer on the wing nut.
7. Remove the dirty cleaner element.

### **INSTALLATION:**

1. Install the air filter primary element into the air filter housing.
2. Check the rubber sealing washer, and make sure it is in place under the wing nut.
3. Tighten the wing nut(s) that secures the primary element in the air filter housing.
4. Assemble the dust shield and the dust pan.
5. Position the dust shield and dust pan to the air filter housing, and secure them with the band clamp wing bolt.

## Air cleaner restriction

Maintenance Check.

## Mechanical Indicator



Never operate the engine without an air cleaner. Intake air must be filtered to prevent dirt and debris from entering the engine and causing premature wear.

**Note:** Do not remove the felt washer from the indicator. The felt washer absorbs moisture.

A mechanical restriction indicator is available to indicate excessive air restriction through a dry-type air cleaner. This instrument can be mounted in the air cleaner outlet or on the instrument panel. The red flag (1) in the window gradually rises as the cartridge loads with dirt. After replacing the cartridge, reset the indicator by pushing the reset button (2).

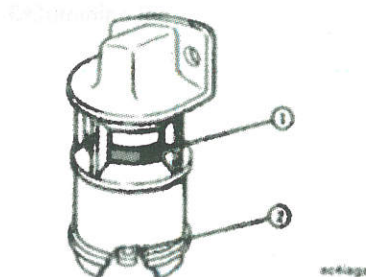

Restriction or vacuum indicators are to be installed as close as possible to the turbocharger air inlet in order to obtain a true indication of restrictions.

## Vacuum Indicator

Vacuum switches actuate a warning light on the instrument panel when the air restriction becomes excessive.

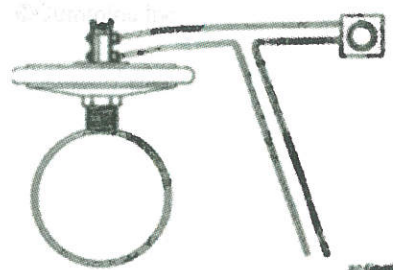

## Industrial Gas Mechanical Indicator

A mechanical restriction indicator is available to indicate excessive air restriction through a dry-type air cleaner. This device is installed on the air cleaner outlet. The red flag (1) in the window gradually rises as the cartridge loads with dirt. When air restriction is indicated the air filter must be replaced. After replacing the cartridge, reset the indicator by pushing the reset button (2).

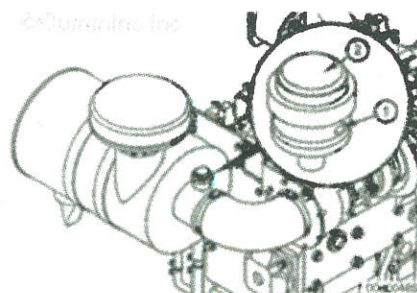

## Charge-Air-Cooler

### Clean and inspect for reuse

If the engine experiences a turbocharger malfunction or any other occasion where oil or debris

is put into the charge-air cooler, the charge-air cooler **must** be cleaned.

Brush away all loose dirt from around the area of the air handling connections to avoid contamination of the interior of the engine.

Remove the charge-air cooler piping and charge-air cooler from the vehicle.

Refer to the OEM service manual.

Flush the charge-air cooler internally with solvent in the opposite direction of normal air flow.

Shake the charge air cooler and lightly tap on the end tanks with a rubber mallet to dislodge trapped debris. Continue flushing until all debris or oil is removed.

**NOTE: Be sure the tubes are in a vertical orientation when flushing.**

If the debris can **not** be totally removed from the charge-air cooler, the charge-air cooler **must** be replaced.

## ⚠ CAUTION ⚠

The charge-air cooler must be rinsed, dried, and cleaned of solvent, oil, and debris, or engine damage will result.

After the charge-air cooler has been thoroughly cleaned of all oil and debris with solvent, wash the charge-air cooler internally with hot soapy water to remove the remaining solvent.

Rinse thoroughly with clean water.

Blow compressed air through the inside of the charge-air cooler in the opposite direction of normal airflow until the charge-air cooler is dry internally.

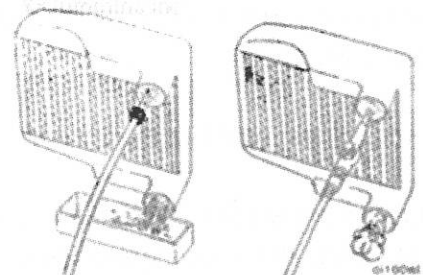
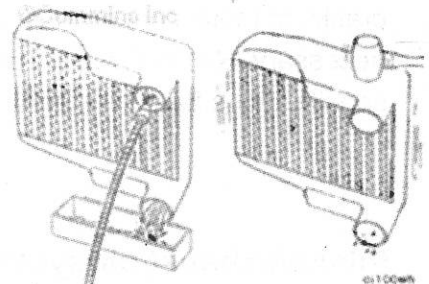
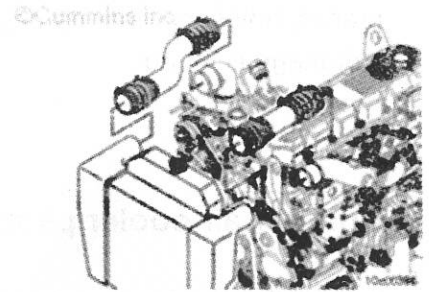

Check the Charge- Air Cooler (CAC) for dirt and debris blocking the radiator fins. Inspect the charge-air cooler for cracks, holes, or other damage. Contact the vehicle, vessel or if damage is found.

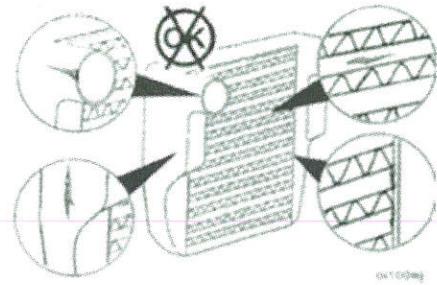

### Charger air cooler plumbing

Inspect the charge air cooler piping and hoses for leaks, holes, cracks or loose connections. Tighten the hose clamps, if necessary. Refer to vehicle or equipment manufacture's specifications for correct torque.

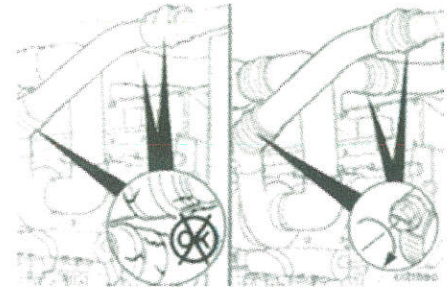

### Intake/exhaust air system leakage inspection

## ⚠ CAUTION ⚠

Engine intake air must be filtered to prevent dirt and debris from entering the engine. If intake air piping is damaged or loose, unfiltered air will enter the engine and cause premature wear.

Inspect for loose clamps or damage between the intake air piping, air cleaner, turbocharger, charge-air cooler and intake manifold.

Check for corrosion of the inlet system piping under the clamps and hoses.

Corrosion can allow corrosive products and dirt to enter the intake system.

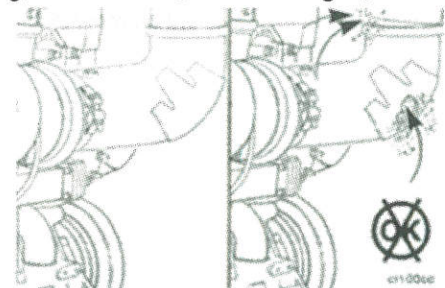

Disassemble and clean as required.

Operate the engine at high idle, and use a solution of soapy water to spot inlet air leaks. If an air leak exists, the soap bubbles will be drawn in with the air.

Replace any damaged pipes, and tighten loose clamps.

## Radiator pressure cap



Don't remove the pressure cap from a hot engine. Wait until the coolant temperature is below 50°C [120°F] before removing the pressure cap. Heated coolant spray or steam can cause personal injury.

Remove the radiator pressure cap.

Make sure the correct radiator pressure cap is being used.  
Recommended minimum pressure is: 103KPa.

Check the rubber seal of the pressure cap for damage.

Inspect radiator fill neck for cracks or other damage.

Refer to the radiator manufacturer for instructions, if the fill neck is damaged.

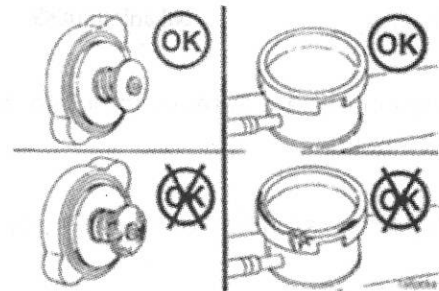

## Battery cables and connections.



Batteries can emit explosive gases. To reduce the possibility of personal injury, always ventilate the compartment before servicing the batteries. To reduce the possibility of arcing, remove the negative (-) battery cable first and attach the negative (-) battery cable last.

If conventional batteries are used, remove cell caps or covers and check electrolyte level.

**Note: Maintenance-free batteries are sealed and it is not necessary to fill additional water.**

Fill each battery cell with distilled water. Refer to battery manufacturers' specification. If distilled water has been added to a dry cell, recharge the battery to mix the added water with the existing battery electrolyte, to prevent incorrect readings.

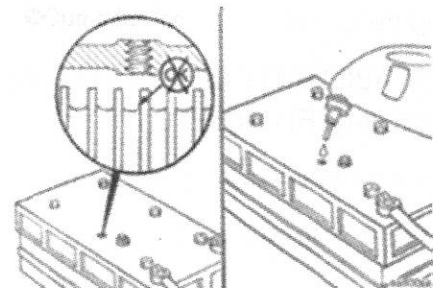

## ⚠ CAUTION ⚠

Do not connect battery charging cables to any electronic control system part. This can damage the electronic control system parts.

Use a carbon-pile load (battery/alternator tester) to test the output amperage of maintenance-free or conventional vent cap batteries. If the output amperage is low, use a battery charger to charge the battery. Refer to the manufacturer's instructions.

Replace the battery if it will **not** charge to the manufacturer's specifications or will **not** maintain a charge.

Inspect battery terminal for loose, broken, or corroded connections.

Repair or replace broken cables or terminals.

If the connections are corroded, remove the cables and use a battery brush to clean the cables and terminals.

Install and tighten battery cables.

Use dielectric grease to coat the battery terminals to prevent corrosion.

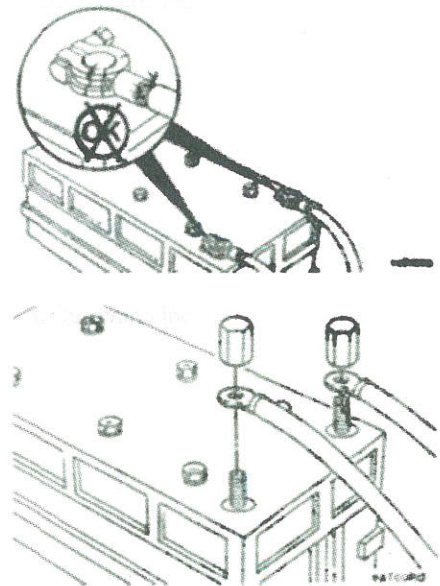

## Overhead

### Preparatory

All overhead lash measurements **must** be made when the engine is cold.

A STABILIZED COOLANT TEMPERATURE **MUST** BE AT 60°C [140°F] OR BELOW.

Remove the rocker lever cover.

### Making Adjustments

Valves and engine brakes **must** be correctly adjusted for the engine to operate efficiently.

Valves and engine brakes **must** be adjusted according to the data shown in **this** section.

The accompanying table gives the adjustment specifications.

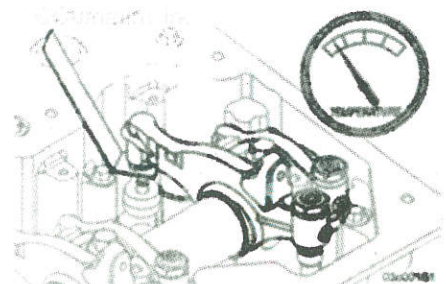

If the valves have been adjusted during troubleshooting or before the scheduled interval, adjustment is **not** required at this time.

#### Valve Adjustment Specifications

intake valve: 0.39mm±0.05mm

exhaust valve: 0.72mm±0.05mm

**NOTE: ALL VALVE AND INJECTOR ADJUSTMENTS MUST BE MADE WHEN THE ENGINE IS COLD, ANY STABILIZED COOLANT TEMPERATURE AT 60° C [140°F] OR BELOW.**

## ▲ WARNING ▲

While repairing engine, do not use remote start motor switch, or any other devices which can engage the starting motor and will cause the high pressure common rail fuel system rotate the crankshaft in engine. Start motor in operation will produce high pressure fuel in fuel system. High-pressure fuel spray can penetrate the skin, resulting in serious personal injury or death. Manual barring tool can be used to turn the crankshaft of the engine being serviced. After crankshaft rotation, it requires to loosen the pump-to-rail fuel line at the rail to release pressure. Keep hands clear of line when loosening, and wear corresponding protective glass.

## ▲ WARNING ▲

Do not straighten a bent fan blade or continue to use a damaged fan. A bent or damaged fan blade can fail during operation and cause personal injury or property damage.

The valve set marks are located on the vibration damper.

The marks align with a pointer on the gear cover.

The indicating arrow may not be easy to find out.

Indicating arrow is located on the lower-left corner of front gear housing.

Use paint pen to mark the indicating arrow for clarity.

Rotate the crankshaft with vibration damper.

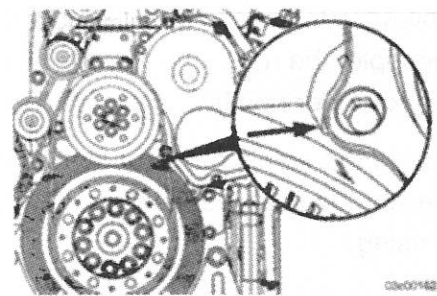

The crankshaft rotation is **clockwise**, as viewed from the front of the engine.

The cylinders are numbered from the front gear cover end of the engine.

The firing order is 1-5-3-6-2-4

Each cylinder has two rocker levers:

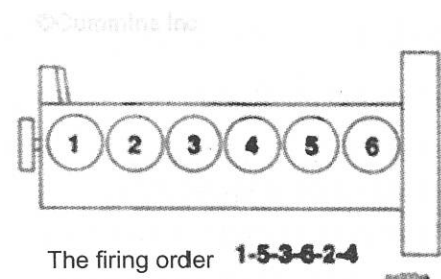

- ☒ The long rocker lever (E) is the exhaust lever.
- ☒ The short rocker lever (I) is the intake lever.

© Cummins Inc.

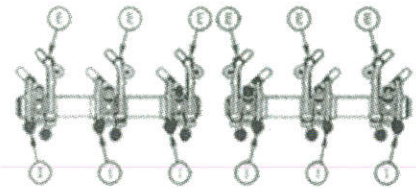

93e00164

Refer to the accompanying figure for the intake and exhaust valve rocker lever locations.

Two crankshaft revolutions are required to adjust all the valves.

**NOTE:** See the example before attempting to begin the adjusting procedure.

Adjust all the valve according to the following valve adjusting sequence table.

After finishing valve adjustment, mark the setting of every valve with marker.

Valve Measurement Sequence		
Crank engine with rotating direction	Damper position	Set Cylinder
Start	A	1
Advance to	B	5
Advance to	C	3
Advance to	A	6
Advance to	B	2
Advance to	C	4
Firing Order is 1-5-3-6-2-4		

The adjustment can begin on any valve set mark. In the following example, the adjustment will begin on the "A" valve set mark with cylinder number 1 valves closed and ready for adjustment.

Rotate the crankshaft **clockwise** until the "A" valve set mark on the vibration damper is aligned with the pointer on the front gear housing.

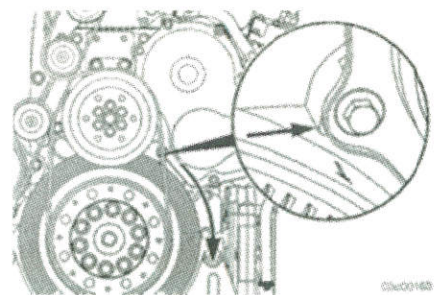

03e00165

The indicating arrow may not be easy to find out. Indicating arrow is located on the lower-left corner of front gear housing.

Use paint pen to mark the indicating arrow for clarity.

Rotate the crankshaft with vibration damper.

WHEN THE "A" MARK IS ALIGNED WITH THE POINTER, THE INTAKE AND EXHAUST VALVES FOR CYLINDER NUMBER 1 **MUST** BE CLOSED. If these conditions are **not** correct, cylinder

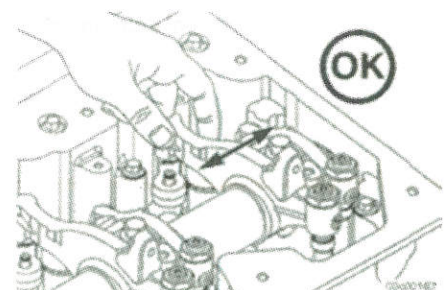

03e00167

number 6 valves **must** be ready to set. Set the valves on the cylinder so that both the intake and exhaust valve rocker lever arms are loose and can be moved from side-to-side.

Both valves are closed when both rocker levers are loose and can be moved from side-to-side.

## The valves

With the "A" valve set mark aligned with the pointer on the front gear housing and both valves closed on the cylinder to be adjusted, loosen the adjusting screw locknuts on the intake and exhaust valves.

Select feeler gauge in accordance with the valve lash specification of the ambient temperature.

valve lash specifications

intake valve:  $0.39\text{mm} \pm 0.05\text{mm}$

exhaust valve:  $0.72\text{mm} \pm 0.05\text{mm}$

Insert the feeler gauge between the top of the crosshead and the rocker lever pad.

Two methods for establishing valve lash clearance are described below.

Either method can be used; however, the torque wrench method has proven to be the most consistent.

It eliminates the need to feel the drag on the feeler gauge.

### Torque Wrench Method

Use the inch-pound torque wrench, Part Number 3376592, normally used to set preload on top-stop injectors, and tighten the adjusting screw.

**Torque Value:** 0.7 N.m [6 in-lb]

### Touch Method

Tighten the adjusting screws with hex wrench, until a slight drag is felt on the feeler gauge.

轻微的阻滯感。

Hold the adjusting screw in the position shown. The adjusting screw **must not** turn when the locknut is tightened.

**Torque Value:**

Without torque wrench adaptor 61 N•m [45 ft-lb]

**Torque Value:**

With torque wrench adaptor (Part Number 3163196) 47 N•m [35 ft-lb]

After tightening the locknut to the correct torque value, check to make sure the feeler gauge will slide backward and forward between the crosshead and the rocker lever with **only** a slight drag.

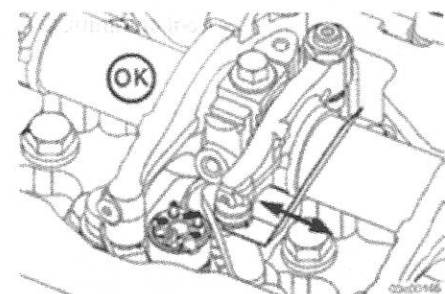
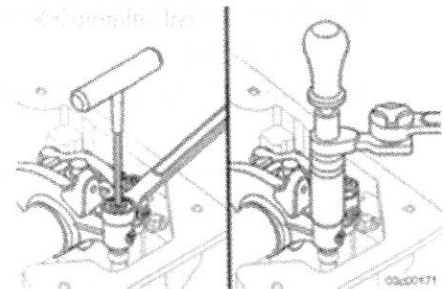
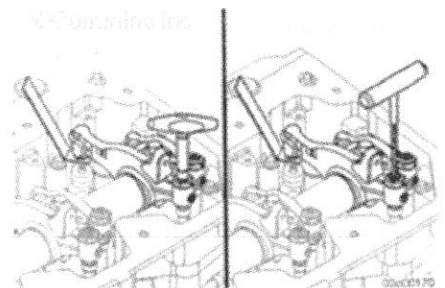
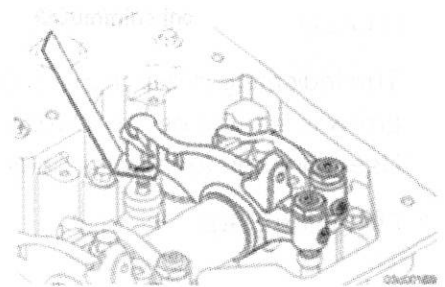
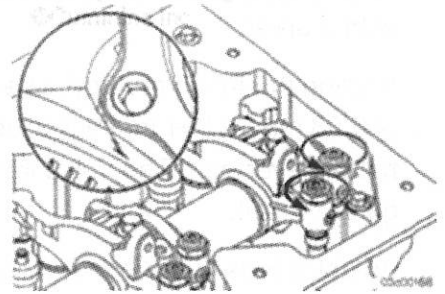

After finishing valve adjustment, mark the setting of every valve with marker.

If using the touch method, attempt to insert a feeler gauge that is 0.03 mm [0.001 in] thicker between the crosshead and the rocker lever pad. The valve lash is **not** correct when the thicker gauge will fit.

Adjust valves of corresponding cylinders and engine brakes (if equipped), rotate crankshaft with vibration damper, and align the next valve setting mark with indicating arrow on the front gear housing.

The indicating arrow may not be easy to find out. Indicating arrow is located on the lower-left corner of front gear housing. Use paint pen to mark the indicating arrow for clarity.

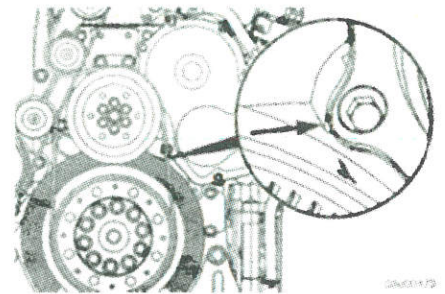
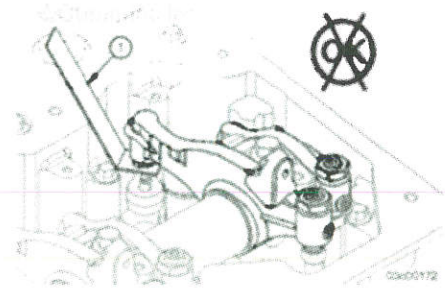

### Finishing Step

- Install the rocker cover(s).
- Operate the engine and check for proper operation and leaks.

## Engine Brakes

### Overview

Engine brake features:

1. Solenoid Valve
2. Location for mounting studs
3. DCEC® HARNESS P-CLIPS POSITION
4. Slave piston adjusting screw
5. Slave pistons
6. Position of mounting bolt.

Engine brake main piston contacts the machined pad (1) on the exhaust rocker (2).

Engine features a 24V electrical system. Compressed brake is only applicable for 24V configuration.

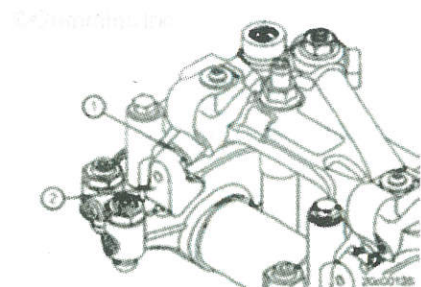
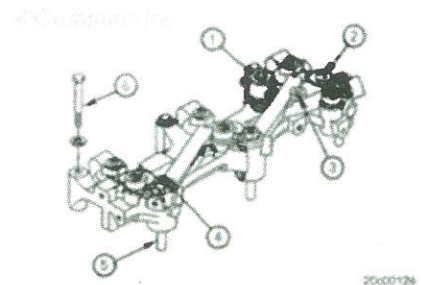

## Initial Check

A stuck of oil flow solenoid valve can prevent the engine brake from starting or performing properly.

To check for a stuck solenoid valve, disconnect the electrical connection to the engine brakes and operate the engine again.

If exhaust gases can be heard escaping past the valves, the solenoid valve or valves **must** be replaced.

Contact an authorized engine brake dealer.

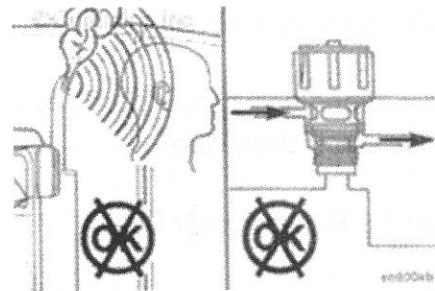
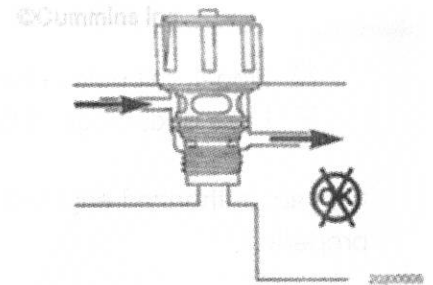
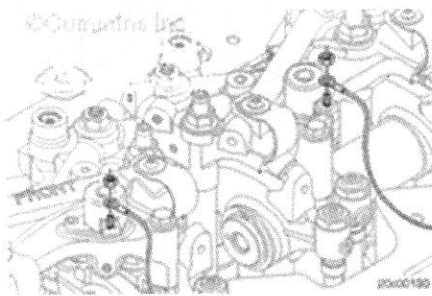

Improper adjustment or secondary piston damage will lead to engine rough running or failure of start.

To check the slave piston, remove the rocker lever cover.

Check slave piston clearance.

Measure and adjust clearance according to "Adjustment" section in this procedure.

Inspect the slave piston for damage.

If the slave piston is damaged, contact an authorized engine brake dealer for repair.

Install the Rocker Lever Cover.

If a sudden drop in lubricating oil pressure Cause the engine to **not** start or run rough, perform the following steps.

Remove the rockver lever cover.

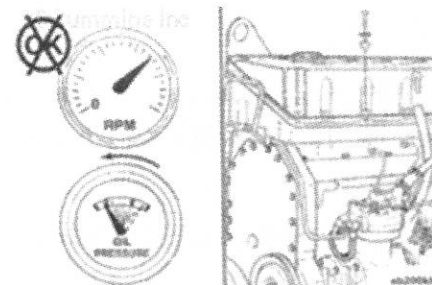
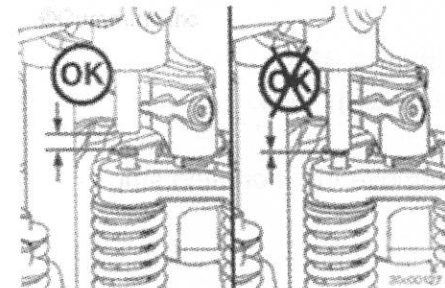
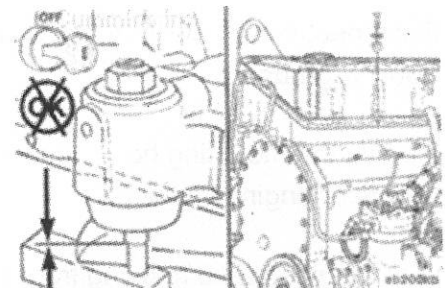

Look for the following:

- Upper solenoid valve seal ring missing or damaged
- Loss or damage of fuel supply pipe O-ring adaptor.

Contact authorized engine brake dealer to solve problems properly.

Install the Rocker Lever Cover.

If the engine is misfiring or has a loss of power:

- Remove rocker lever cover.

Measure and adjust clearance according to "Adjustment" section in this procedure.

Install the Rocker Lever Cover.

## REMOVE

Disconnect the connection between the terminal and solenoid supply & ground wire.

Remove the mounting bolts and its hex mounting nuts on the left side of engine brake.

Lift up engine brake housing from stud.

Remove assembly spacer from mounting studs.

Remove the mounting studs.

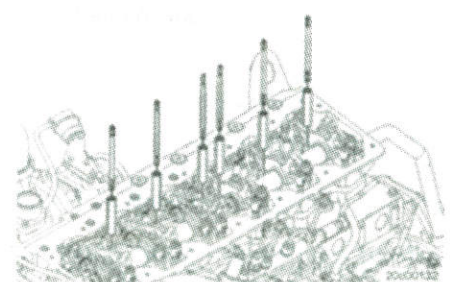
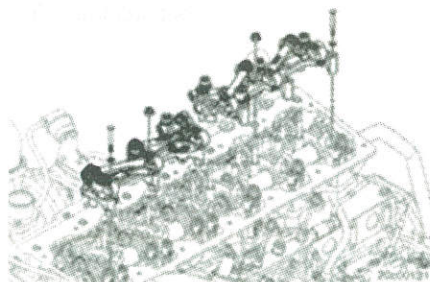

**NOTE:** If engine brake cannot be re-installed, remove fuel supply line adaptor and block the supply hole in the rocker pedestal.

Fix all the loosening cable in cable tray.

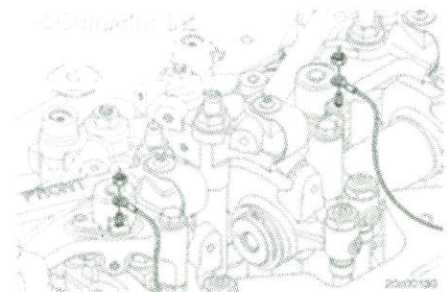
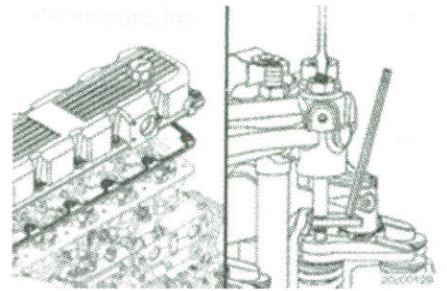
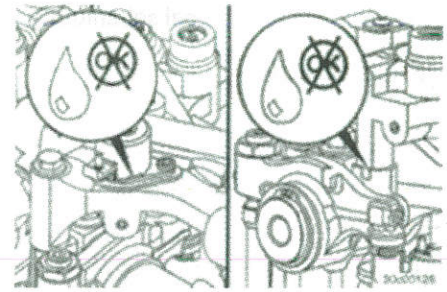
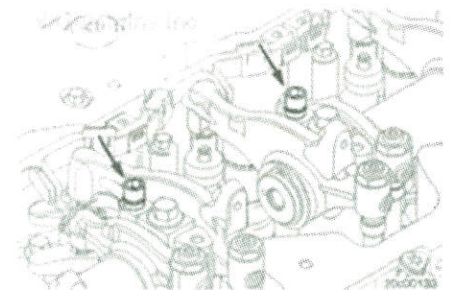

## Claen and inspect for reuse



When using solvents, acids, or alkaline materials for cleaning, follow the manufacturer's recommendations for use. Wear goggles and protective clothing to reduce the possibility of personal injury.

Wear appropriate eye and face protection when using compressed air. Flying debris and dirt can cause personal injury.

Use an approved solvent to clean the brake housings. Dry using compressed air.

Inspect the housings for any missing or damaged parts.

Inspect the solenoid and terminals for damage.

Remove solenoid from housing, and check pin assembly for operation.

- Remove the inlet screen
- Press button with forefinger and press pin at the bottom with thumb to fix solenoid.
- Alternately push on the button and pin. Pin and button shall be moved freely.

Check terminal resistance with ohmmeter.

- 24V non-return solenoid 32.6 - 39.8Ω
- Replace the solenoid if the resistance measured is **not** to specification.

Check that screen **is not** cracked or damaged. Check and confirm both sides of the terminal without abrasion. Before tightening the solenoid, confirm the solenoid has seated in the bore. Tighten solenoid hold-down bolts.

**Torque Value:** 10 N.m [89 in-lb]

Check and confirm the wiring connector is held on the studs. Tighten the fasteners.

**Torque Value:** 1.2 N.m [11 in-lb]

Check the solenoid sealing ring for abrasion or damage. If damaged, apply a thin oil on the new sealing ring, and replace with it.

If the solenoid is not within above specifications, it must be replaced. Contact authorized engine brake dealer to solve problems properly.

Apply a thin film of clean 15W-40 oil to the machined surfaces.

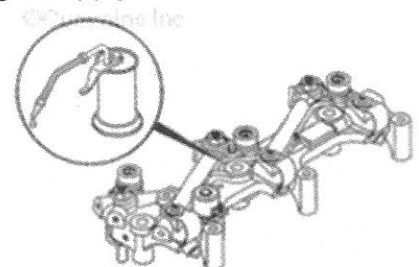
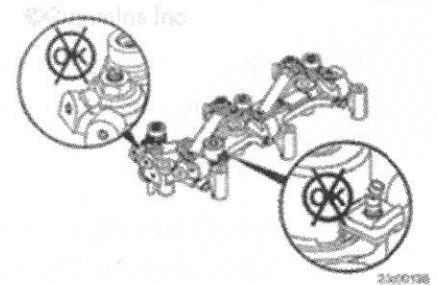
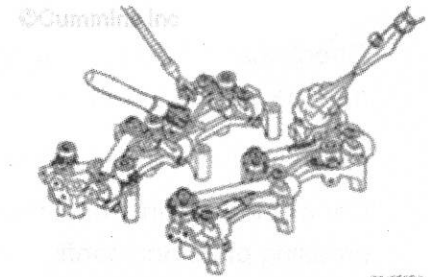

Check supply line O-ring adaptor for damage.

Check mounting stud and spacer for corrosion and other damage.

Check the main piston retaining spring for damage.

Check exhaust rocker arm brake gasket and observe them for loss or damage.

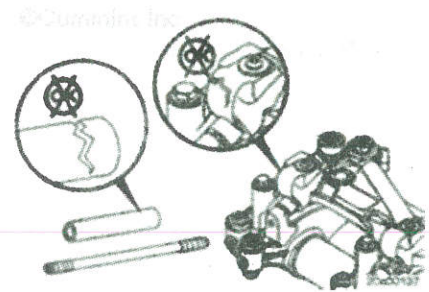

## Mount

Check that the correct wiring harness is installed. The engine may be equipped with the brake wiring or non-brake wiring.

If not used, install the correct harness.

Check and confirm installation of compressor brake jump pressing plate and confirm the actuator pin orientated to engine camshaft.

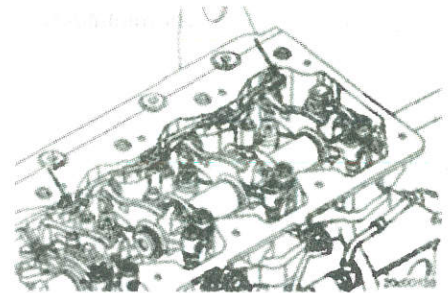

Oil supply connector shall installed inside the rocker pedestal. If the oil supply connector is not installed, execute the following operation:

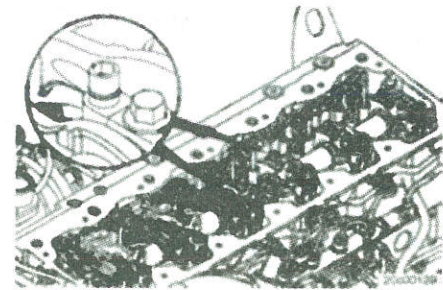

- Remove every pedestal plug from oil supply hole
- Make sure the O-ring has no damage and is installed on the adaptor.

Install the oil supply connector into the rocker pedestal.

Install the six mounting studs into the cylinder head. Allen socket shall orientate upward.

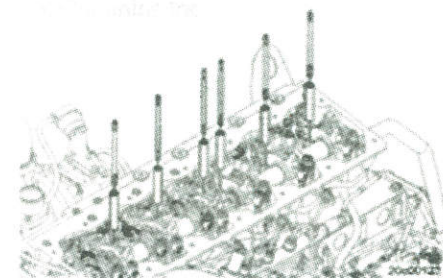

Tighten studs manually until its bottom accesses threaded hole.

Install a mounting spacer on each studs.

Install the brake housing with "Front" mark to studs of cylinder No.1 to No.3.

Install the brake housing with "Rear" mark to studs of cylinder No.4 to No.6.

Install the mounting bolt and gasket into the rocker pedestalal bracket through the left side of brake housing.

Install the mounting nuts onto the mounting studs.

Tighten all fasteners.

Tighten engine brake mounting bolts, every brakes according to the sequence shown in diagram from center to external.

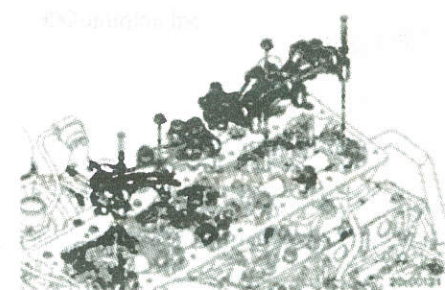

**Torque Value:** 113 N.m [83 ft-lb]

Tighten engine brake mounting bolts, every brakes according to the sequence shown in diagram from center to external.

**Torque Value:** 33 N.m [24 ft-lb]

Connect solenoid valve power and ground wires and terminal, and tighten.

**Torque Value:** 1.1 N.m [10 in-lb]

Adjust the secondary piston clearance. See the Adjustment section in this procedure.

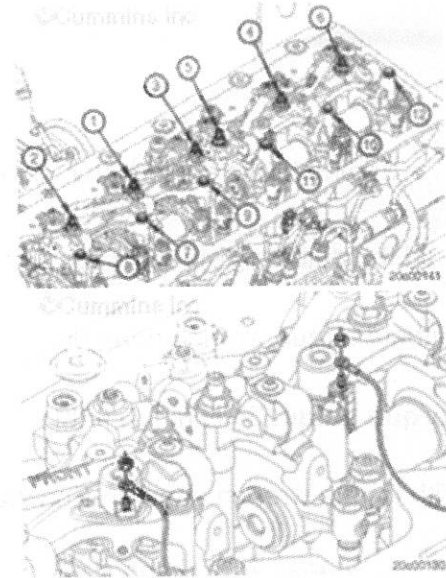

### Making Adjustments



Do not overtighten the adjusting screws. Damage to the engine can occur.

Improper clearance will damage the engine.

To obtain maximum brake operating efficiency and prevent engine damage by piston-to-valve contact, complete the following instructions carefully.

Adjust the exhaust valves on the appropriate cylinder.

After adjusting the exhaust valves on the appropriate cylinder, insert the correct feeler gauge.

Loosen locknut on slave piston adjusting screw.

Rotate engine to required position of the front engine vibration damper.

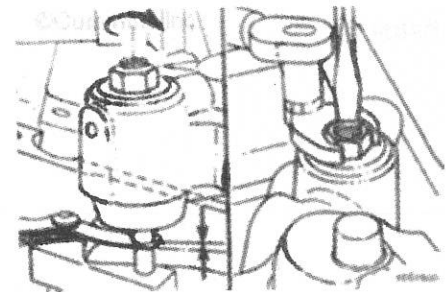

Damper position	Adjust the corresponding cylinders
A	1 and 6
B	2 and 5
C	3 and 4

Use DCEC® repair tool (part number 4919338) to adjust the brake lash of corresponding cylinders.

## Measurements

	mm	inch
Engine brake slave piston clearance	3.2 ±0.051	0.118 ±0.002

Hold the adjusting screw in position and tighten the locknut.

Without torque wrench adapter

**Torque Value:** 34 N.m [25 ft-lb]

With torque wrench adapter, Part Number 3163196

**Torque Value:** 30 N.m [22 ft-lb]

After the slave piston adjusting screw locknut is tightened to the correct torque value, check the clearance with the feeler gauge again.

## Finishing Step

Install the Rocker Lever Cover.

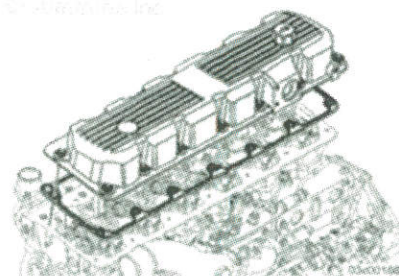

### 3: Maintenance content for every 400 hours or 4 months

All maintenance checks and inspections listed in previous maintenance intervals **must** also be performed at this time, in addition to those listed under this maintenance interval.

#### Fuel filter(s)

##### Overview

The fuel system requires the use of two fuel filters. The suction side filter **must** have the following characteristics:

- Water-separating
- 7-micron rating
- Water-in-fuel sensor with shunt resistor
- Water-drain valve.
- Engine mounted.

The pressure-side filters **must** have the following characteristics:

- 3-micron rating
- Engine mounted.

##### Preparatory .

### ▲ WARNING ▲

Batteries can emit explosive gases. To reduce the possibility of personal injury, always ventilate the compartment before servicing the batteries. To reduce the possibility of arcing, remove the negative (-) battery cable first and attach the negative (-) battery cable last.

Wear appropriate eye and face protection when using compressed air. Flying debris and dirt can cause personal injury.

### ▲ WARNING ▲

When using steam, wear safety glasses or a face shield, as well as protective clothing. Hot steam can cause serious personal injury.

### ▲ CAUTION ▲

Clean all fittings before disassembly. Dirt or contaminants can damage the fuel system.

Before servicing **any** fuel system components, (such as fuel lines, fuel pump, injectors, etc.) which would expose the fuel system or internal engine component to potential contaminants prior to

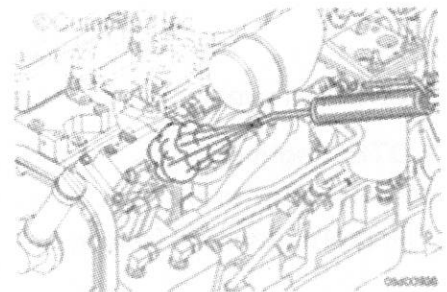

disassembly, clean the fittings, mounting hardware, and the area around the component to be removed. If the surrounding areas are **not** cleaned, dirt or contaminants can be introduced into the fuel system and engine, resulting in damage to the fuel system and engine.

Clean fuel filter head adapter, connector and mating components with contact cleaner, Part Number 3824510 or equivalent.

- Disconnect battery. Refer to the OEM repair instructions.
- Steam clean the engine.

## REMOVE

### **WARNING**

Depending on the circumstance, diesel fuel is flammable. When inspecting or performing service or repairs on the fuel system, to reduce the possibility of fire and resulting in severe personal injury, death, or property damage, never smoke or allow sparks or flames (such as pilot lights, electrical switches, or welding equipment) in the work area.

Remove the fuel filter with filter wrench, Part Number 3400157.

Be sure the seal ring does **not** stick to the filter head.

Remove the seal ring with an o-ring pick, if necessary.

### Mount

Use the correct filter(s) for the engine. It must remove a minimum of 98.7 percent of free and emulsified water. It **must** also reach the removal efficiency for 3-micron particle.

Apply a thin coating of clean engine oil to the filter gasket surface and the center seal.

**NOTE: Dongfeng Cummins ®/Fleetguard® filter is equipped with disposable filter elements, which can prevent fuel from entering the clean side of the filter media when in pre-injection.**

### **CAUTION**

Mechanical overtightening of the filter can distort the threads and damage the fuel filter seal.

**NOTE: Engines equipped with priming pumps do not require the fuel filter to be filled prior to installation if the following filling procedure is followed.**

Install the filter onto the filter head.

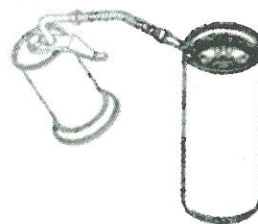
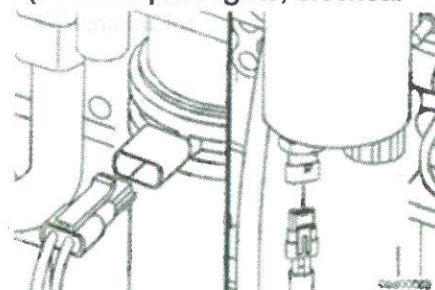

0600019

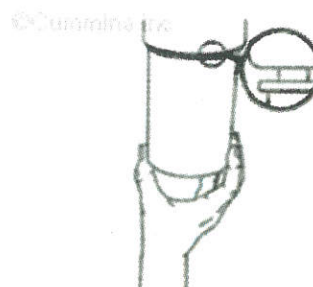

0720009

Turn the filter until the gasket contacts the filter head surface.

Tighten the filter an additional 3/4 of a turn after the gasket contacts the filter head surface, or as specified by the manufacturer.

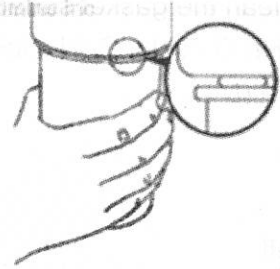

07200040

### Finishing Step

## ▲ WARNING ▲

Batteries can emit explosive gases. To reduce the possibility of personal injury, always ventilate the compartment before servicing the batteries. To reduce the possibility of arcing, remove the negative (-) battery cable first and attach the negative (-) battery cable last

Connect the battery. Refer to the OEM repair instructions.

Prime the fuel system.

Operate the engine and inspect for leaks.

### Lubricating Oil & Filters

## ▲ WARNING ▲

Used engine oil can be carcinogenic and cause reproductive toxicity. Avoid inhalation vapors, ingestion, and prolonged contact with used engine oil. If not reused, dispose of in accordance with local environmental regulations.

## ▲ WARNING ▲

To reduce the possibility of personal injury, avoid direct contact of hot oil with the skin.

Engine oil and oil filter must be changed every 400 hours or 4 months (whichever occurs first) operation.

Operate the engine until the water temperature reaches 60°C [140°F]. Shut the engine off.

Remove the oil drain plug from the bottom of the oil pan to completely drain oil.

Clean the area around the lubricating oil filter head.

Use oil filter wrench to remove the oil filter(s).

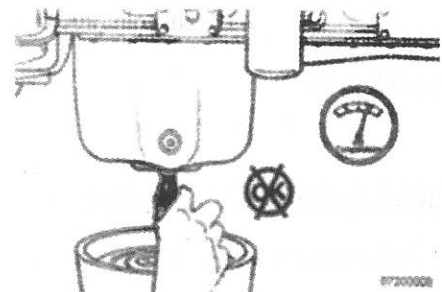

07200008

Clean the gasket surface on the lubricating oil filter head.  
THE O-RING CAN stick on the filter head; **make sure** it is removed.

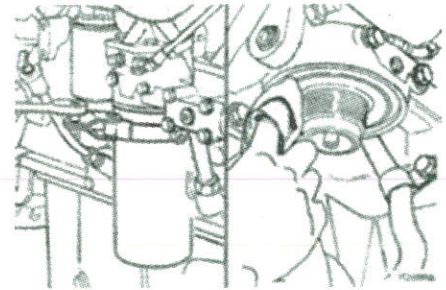

Fill

## ⚠ CAUTION ⚠

Never replace a lubricating filter with any other lubricating filter without verifying adequate clearance with suspension and/or chassis at extremes of travel. Damage to the engine can occur.

Use the correct oil filter for the engine.

DONGFENG CUMMINS ENGINE COMPANY REQUIRES THE USE OF A LUBRICATING OIL FILTER THAT MEETS DCEC® SOURCE APPROVED METHOD (SAM) 10,765.

## ⚠ CAUTION ⚠

Lack of lubrication due to no oil in the oil filter leads to severe engine harm.

## ⚠ CAUTION ⚠

Mechanical overtightening of the lubricating oil filter can distort the threads or damage the lubricating oil filter seal.

Fill the filter with clean oil. Choose the correct oil with correct amount for your operating climate.

Apply a light film of clean oil to the gasket sealing surface before installing the new filter.

Install the filter on the filter head. Tighten until the gasket contacts the filter head surface.

Use oil filter wrench, Part Number 3400157, to tighten the filter to the specifications supplied with the filter.

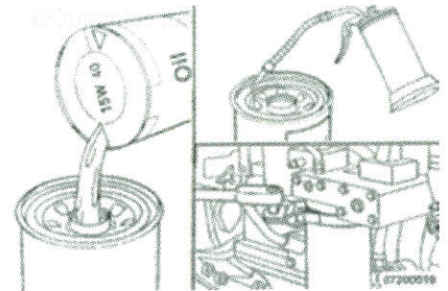

Clean and check the oil drain plug threads and the seal surface.

Install drain plug from both sides of sump for oil pan.

**Torque Value:** 80 N.m [59 ft-lb]

**Note:** Check the torque of the side and bottom oil drain plugs to make sure both are tight.

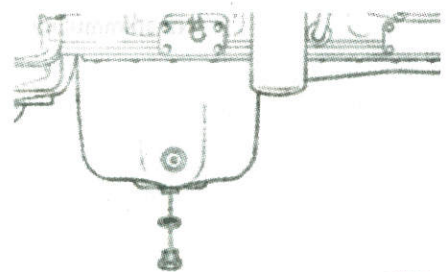

Fill the engine with clean lubricating oil to the h (high) mark on the dipstick.

Mark. Take the following steps to confirm the total system volume (including filter).

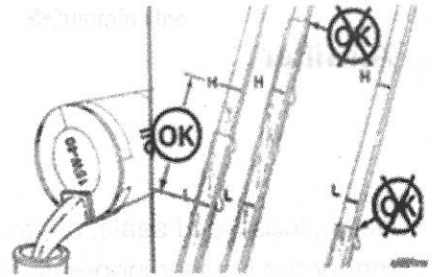

## △ CAUTION △

Engine oil pressure must be indicated on the gauge within 15 seconds after starting. If the oil pressure is not registered within 15 seconds, shut off the engine immediately to prevent engine damage. Confirm the correct oil level in the oil pan.

Operate the engine at idle speed to inspect for leaks at the filter(s) and the drain plug.

Shut off engine. Wait approximately 10 minutes to let the lubricating oil from the upper parts of the engine drain back into the lubricating oil pan.

Check the lubricating oil level again. As necessary, Add oil to the H (high) mark on the dipstick.

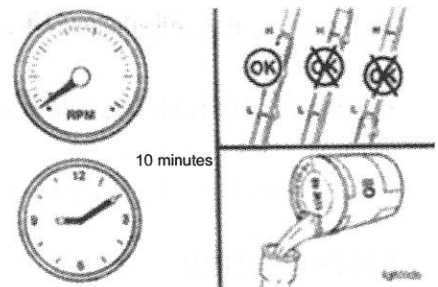
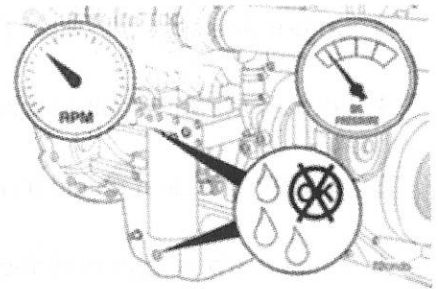

## COOLANTS

### △ CAUTION △

Overconcentration of coolant or use of high silicate coolant can damage the engine.

Coolant must be genuine Dongfeng Cummins long life organic coolant.

Antifreeze is essential in all climates.

Antifreeze broadens the operating temperature range by lowering the coolant freezing point and by raising its boiling point.

The coolant drain interval usually is 2,400 hours or 24 months (if the coolant quantity is enough and no leaks).

## Air filter



Holes, loose-end seals, dented sealing surfaces, corrosion of pipes, and other forms of damage render the cleaner inoperative and require immediate element replacement.

### Remove:

1. Before disassembly, wipe dirt from the cover and the upper portion of the air cleaner.
2. Loosen the wing bolt(s), and remove the band clamp securing the dust pan.
3. Remove the dust shield from the dust pan.
4. Clean the dust pan and dust shield.
5. Remove the wing nut(s) that secures the air filter primary element in the air filter housing.
6. Inspect the rubber sealing washer on the wing nut.
7. Remove the dirty cleaner element.

### INSTALLATION:

1. Install the air filter primary element into the air filter housing.
2. Check the rubber sealing washer, and make sure it is in place under the wing nut.
3. Tighten the wing nut(s) that secures the primary element in the air filter housing.
4. Assemble the dust shield and the dust pan.
5. Position the dust shield and dust pan to the air filter housing, and secure them with the band clamp wing bolt.

## Air cleaner restriction

Maintenance Check.

## Mechanical Indicator



Never operate the engine without an air cleaner. Intake air must be filtered to prevent dirt and debris from entering the engine and causing premature wear.

**Note: Do not remove the felt washer from the indicator. The felt washer absorbs moisture.**

A mechanical restriction indicator is available to indicate excessive air restriction through a dry-type air cleaner. This instrument can be mounted in the air cleaner outlet or on the instrument panel. The red flag (1) in the window gradually rises as the cartridge loads with dirt. After replacing the cartridge, reset the indicator by pushing the reset button (2).

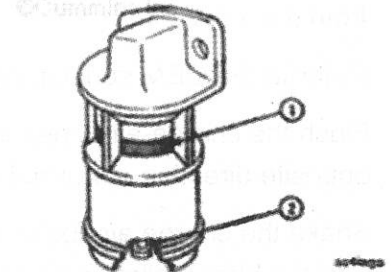

Restriction or vacuum indicators are to be installed as close as possible to the turbocharger air inlet in order to obtain a true indication of restrictions.

## Vacuum Indicator

Vacuum switches actuate a warning light on the instrument panel when the air restriction becomes excessive.

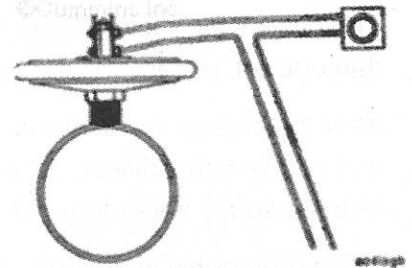

## Industrial Gas Mechanical Indicator

A mechanical restriction indicator is available to indicate excessive air restriction through a dry-type air cleaner. This device is installed on the air cleaner outlet. The red flag (1) in the window gradually rises as the cartridge loads with dirt. When air restriction is indicated the air filter must be replaced. After replacing the cartridge, reset the indicator by pushing the reset button (2).

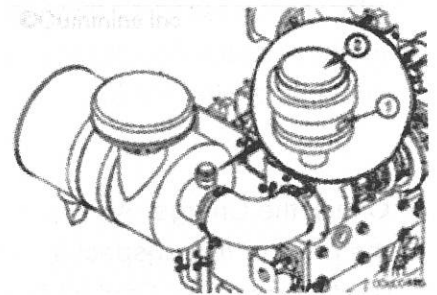

## Charge-Air-Cooler

Claen and inspect for reuse

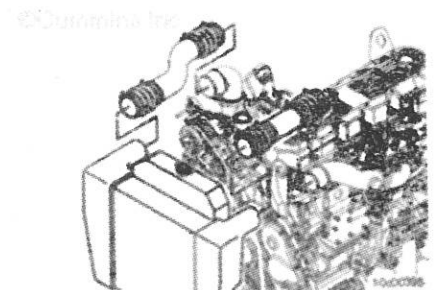

If the engine experiences a turbocharger malfunction or any other occasion where oil or debris is put into the charge-air cooler, the charge-air cooler **must** be cleaned.

Brush away all loose dirt from around the area of the air handling connections to avoid contamination of the interior of the engine.

Remove the charge-air cooler piping and charge-air cooler from the vehicle.

Refer to the OEM service manual.

Flush the charge-air cooler internally with solvent in the opposite direction of normal air flow.

Shake the charge air cooler and lightly tap on the end tanks with a rubber mallet to dislodge trapped debris. Continue flushing until all debris or oil is removed.

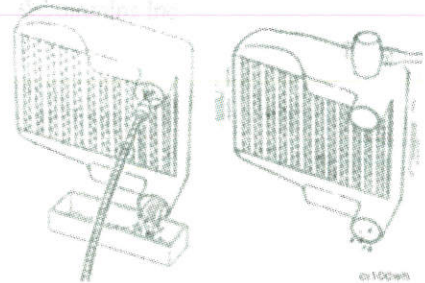

**NOTE: Be sure the tubes are in a vertical orientation when flushing.**

If the debris can **not** be totally removed from the charge-air cooler, the charge-air cooler **must** be replaced.

## ⚠ CAUTION ⚠

The charge-air cooler must be rinsed, dried, and cleaned of solvent, oil, and debris, or engine damage will result.

After the charge-air cooler has been thoroughly cleaned of all oil and debris with solvent, wash the charge-air cooler internally with hot soapy water to remove the remaining solvent.

Rinse thoroughly with clean water.

Blow compressed air through the inside of the charge-air cooler in the opposite direction of normal airflow until the charge-air cooler is dry internally.

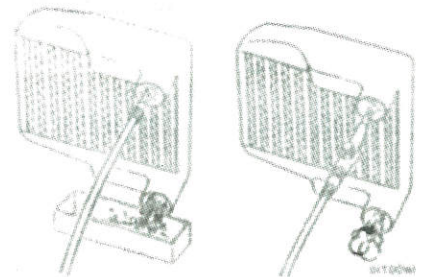

Check the Charge- Air Cooler (CAC) for dirt and debris blocking the radiator fins. Inspect the charge-air cooler for cracks, holes, or other damage. Contact the vehicle, vessel or if damage is found.

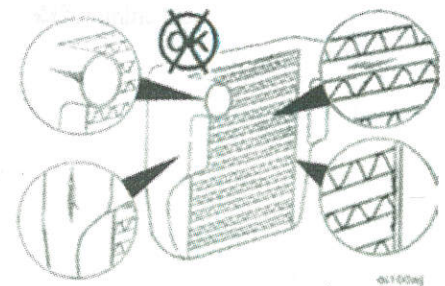

## Charger air cooler plumbing

Inspect the charge air cooler piping and hoses for leaks, holes, cracks or loose connections. Tighten the hose clamps, if necessary. Refer to vehicle or equipment manufacture's specifications for correct torque.

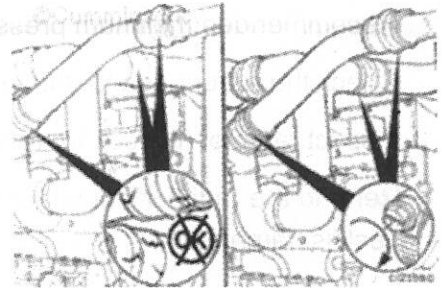

## Intake/exhaust air system leakage inspection



Engine intake air must be filtered to prevent dirt and debris from entering the engine. If intake air piping is damaged or loose, unfiltered air will enter the engine and cause premature wear.

Inspect for loose clamps or damage between the intake air piping, air cleaner, turbocharger, charge-air cooler, and intake manifold.

Check for corrosion of the inlet system piping under the clamps and hoses.

Corrosion can allow corrosive products and dirt to enter the intake system.

Disassemble and clean as required.

Operate the engine at high idle, and use a solution of soapy water to spot inlet air leaks. If an air leak exists, the soap bubbles will be drawn in with the air.

Replace any damaged pipes, and tighten loose clamps.

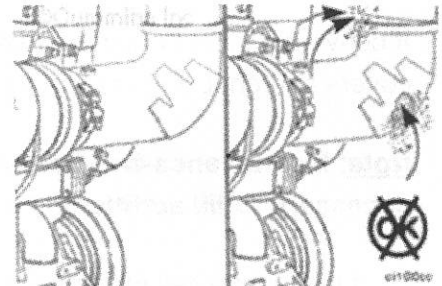

## Radiator pressure cap



Don't remove the pressure cap from a hot engine. Wait until the coolant temperature is below 50°C [120°F] before removing the pressure cap. Heated coolant spray or steam can cause personal injury.

Remove the radiator pressure cap.

Make sure the correct radiator pressure cap is being used.  
Recommended minimum pressure is: 103KPa.

Check the rubber seal of the pressure cap for damage.

Inspect radiator fill neck for cracks or other damage.

Refer to the radiator manufacturer for instructions, if the fill neck is damaged.

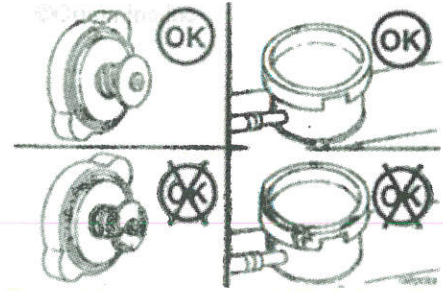

## Battery cables and connections.

### ▲ WARNING ▲

Batteries can emit explosive gases. To reduce the possibility of personal injury, always ventilate the compartment before servicing the batteries. To reduce the possibility of arcing, remove the negative (-) battery cable first and attach the negative (-) battery cable last.

If conventional batteries are used, remove cell caps or covers and check electrolyte level.

**Note: Maintenance-free batteries are sealed and it is not necessary to fill additional water.**

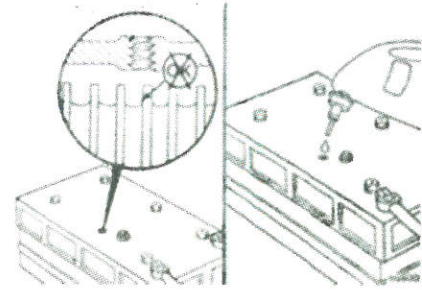

Fill each battery cell with distilled water. Refer to battery manufacturers' specification. If distilled water has been added to a dry cell, recharge the battery to mix the added water with the existing battery electrolyte, to prevent incorrect readings.

### ▲ CAUTION ▲

Do not connect battery charging cables to any electronic control system part. This can damage the electronic control system parts.

Use a carbon-pile load (battery/alternator tester) to test the output amperage of maintenance-free or conventional vent cap batteries. If the output amperage is low, use a battery charger to charge the battery. Refer to the manufacturer's instructions.

Replace the battery if it will not charge to the manufacturer's specifications or will not maintain a charge.

Inspect battery terminal for loose, broken, or corroded connections.

Repair or replace broken cables or terminals.

If the connections are corroded, remove the cables and use a battery brush to clean the cables and terminals.

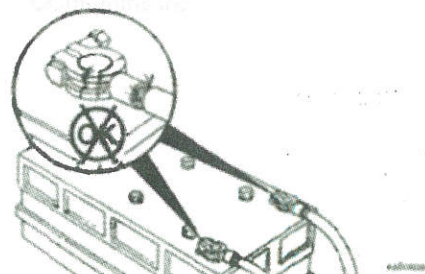

Install and tighten battery cables.

Use dielectric grease to coat the battery terminals to prevent corrosion.

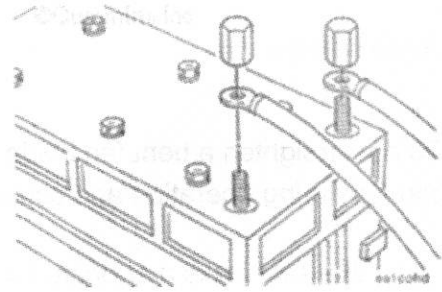

## Overhead

### Preparatory

All overhead lash measurements **must** be made when the engine is cold.

A STABILIZED COOLANT TEMPERATURE **MUST** BE AT 60°C [140°F] OR BELOW.

Remove the rocker lever cover.

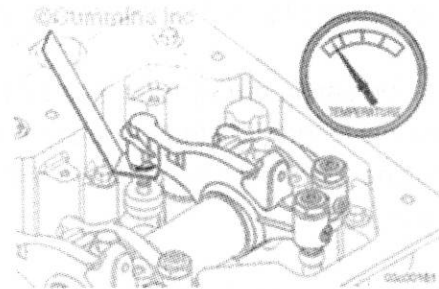

### Making Adjustments

Valves and engine brakes **must** be correctly adjusted for the engine to operate efficiently.

Valves and engine brakes **must** be adjusted according to the data shown in this section.

The accompanying table gives the adjustment specifications.

If the valves have been adjusted during troubleshooting or before the scheduled interval, adjustment is **not** required at this time.

Valve Adjustment Specifications

intake valve: 0.39mm±0.05mm

exhaust valve: 0.72mm±0.05mm

**NOTE: ALL VALVE AND INJECTOR ADJUSTMENTS MUST BE MADE WHEN THE ENGINE IS COLD, ANY STABILIZED COOLANT TEMPERATURE AT 60° C [140°F] OR BELOW.**

## ⚠ WARNING ⚠

While repairing engine, do not use remote start motor switch, or any other devices which can engage the starting motor and will cause the high pressure common rail fuel system rotate the crankshaft in engine. Start motor in operation will produce high pressure fuel in fuel system. High-pressure fuel spray can penetrate the skin, resulting in serious personal injury or death. Manual barring tool can be used to turn the crankshaft of the engine being serviced. After crankshaft rotation, it requires to loosen the pump-to-rail fuel line at the rail to release pressure. Keep hands clear of line when loosening, and wear corresponding protective glass.

## ⚠ WARNING ⚠

Do not straighten a bent fan blade or continue to use a damaged fan. A bent or damaged fan blade can fail during operation and cause personal injury or property damage.

The valve set marks are located on the vibration damper.

The marks align with a pointer on the gear cover.

The indicating arrow may not be easy to find out. Indicating arrow is located on the lower-left corner of front gear housing. Use paint pen to mark the indicating arrow for clarity.

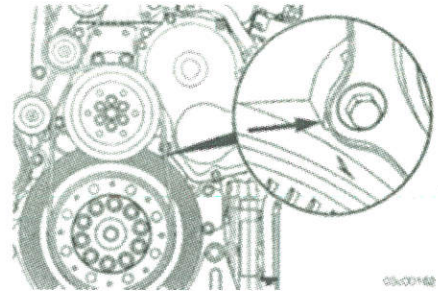

Rotate the crankshaft with vibration damper.

The crankshaft rotation is **clockwise**, as viewed from the front of the engine.

The cylinders are numbered from the front gear cover end of the engine.

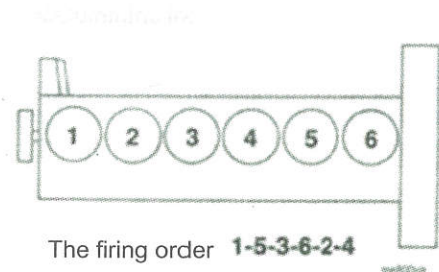

The firing order is 1-5-3-6-2-4

Each cylinder has two rocker levers:

- The long rocker lever (E) is the exhaust lever.
- The short rocker lever (I) is the intake lever.

Refer to the accompanying figure for the intake and exhaust valve rocker lever locations.

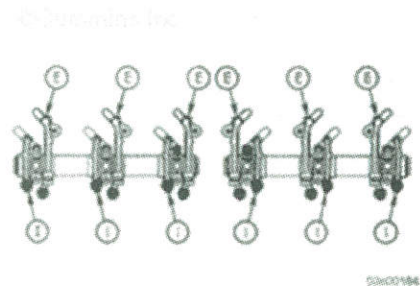

Two crankshaft revolutions are required to adjust all the valves.

**NOTE:** See the example before attempting to begin the adjusting procedure.

Adjust all the valve according to the following valve adjusting sequence table.

After finishing valve adjustment, mark the setting of every valve with marker.

Valve Measurement Sequence		
Crank engine with rotating direction	Damper position	Set Cylinder
Start	A	1
Advance to	B	5
Advance to	C	3
Advance to	A	6
Advance to	B	2
Advance to	C	4
Firing Order is 1-5-3-6-2-4		

The adjustment can begin on any valve set mark. In the following example, the adjustment will begin on the "A" valve set mark with cylinder number 1 valves closed and ready for adjustment.

Rotate the crankshaft **clockwise** until the "A" valve set mark on the vibration damper is aligned with the pointer on the front gear housing.

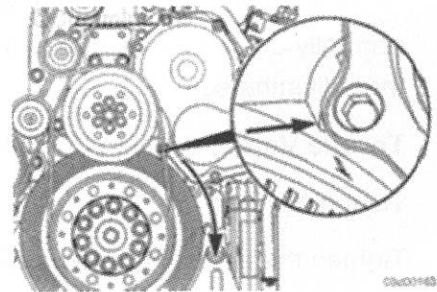

The indicating arrow may not be easy to find out. Indicating arrow is located on the lower-left corner of front gear housing.

Use paint pen to mark the indicating arrow for clarity.

Rotate the crankshaft with vibration damper.

WHEN THE "A" MARK IS ALIGNED WITH THE POINTER, THE INTAKE AND EXHAUST VALVES FOR CYLINDER NUMBER 1 **MUST** BE CLOSED. If these conditions are **not** correct, cylinder number 6 valves **must** be ready to set. Set the valves on the cylinder so that both the intake and exhaust valve rocker lever arms are loose and can be moved from side-to-side.

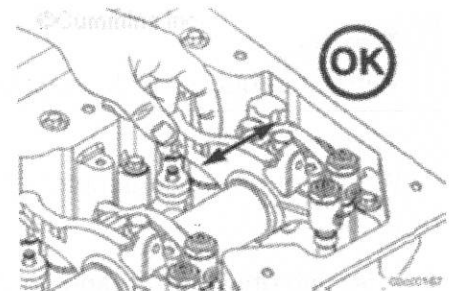

Both valves are closed when both rocker levers are loose and can be moved from side-to-side.

### The valves

With the "A" valve set mark aligned with the pointer on the front gear housing and both valves closed on the cylinder to be adjusted, loosen the adjusting screw locknuts on the intake and exhaust valves.

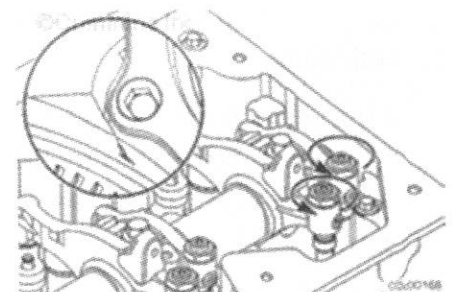

Select feeler gauge in accordance with the valve lash specification of the ambient temperature.

## Valve lash specifications

Intake valve:  $0.39\text{mm} \pm 0.05\text{mm}$

Exhaust valve:  $0.72\text{mm} \pm 0.05\text{mm}$

Insert the feeler gauge between the top of the crosshead and the rocker lever pad.

Two methods for establishing valve lash clearance are described below.

Either method can be used; however, the torque wrench method has proven to be the most consistent.

It eliminates the need to feel the drag on the feeler gauge.

### Torque Wrench Method

Use the inch-pound torque wrench, Part Number 3376592, normally used to set preload on top-stop injectors, and tighten the adjusting screw.

**Torque Value:** 0.7 N.m [6 in-lb]

### Touch Method

Tighten the adjusting screws with hex wrench, until a slight drag is felt on the feeler gauge.

Hold the adjusting screw in the position shown. The adjusting screw **must not** turn when the locknut is tightened.

#### Torque Value:

Without torque wrench adaptor 61 N•m [45 ft-lb]

#### Torque Value:

With torque wrench adaptor (Part Number 3163196) 47 N•m [35 ft-lb]

After tightening the locknut to the correct torque value, check to make sure the feeler gauge will slide backward and forward between the crosshead and the rocker lever with **only** a slight drag.

After finishing valve adjustment, mark the setting of every valve with marker.

if using the touch method, attempt to insert a feeler gauge that is 0.03 mm [0.001 in] thicker between the crosshead and the rocker lever pad. The valve lash is **not** correct when the thicker gauge will fit.

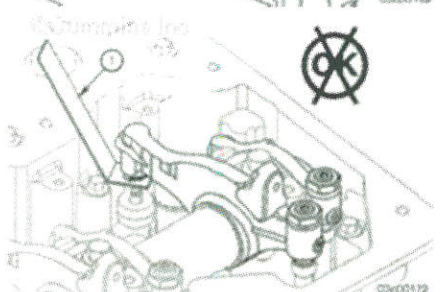
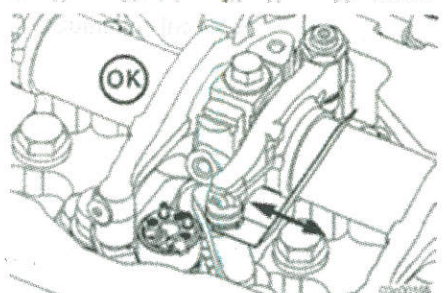
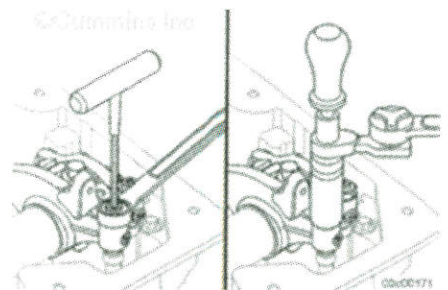
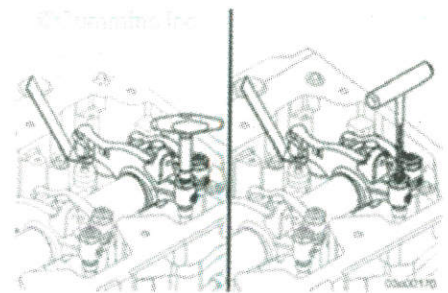
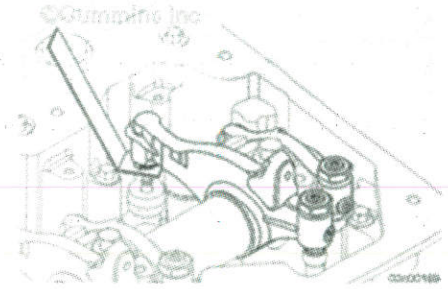

Adjust valves of corresponding cylinders and engine brakes (if equipped), rotate crankshaft with vibration damper, and align the next valve setting mark with indicating arrow on the front gear housing.

The indicating arrow may not be easy to find out. Indicating arrow is located on the lower-left corner of front gear housing. Use paint pen to mark the indicating arrow for clarity.

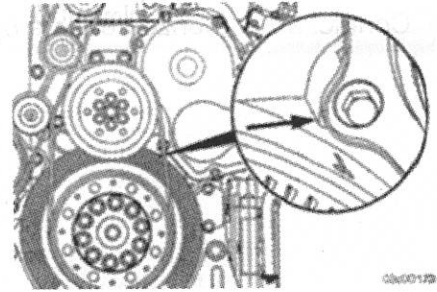

### Finishing Step

- Install the rocker cover(s).
- Operate the engine and check for proper operation and leaks.

## Engine Brakes

### Overview

Engine brake features:

7. Solenoid Valve
8. Location for mounting studs
9. DCEC® HARNESS P-CLIPS POSITION
10. Slave piston adjusting screw
11. Slave pistons
12. Position of mounting bolt.

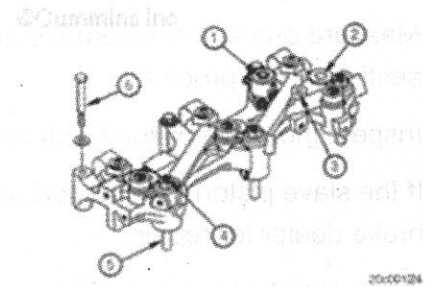

Engine brake main piston contacts the machined pad (1) on the exhaust rocker (2).

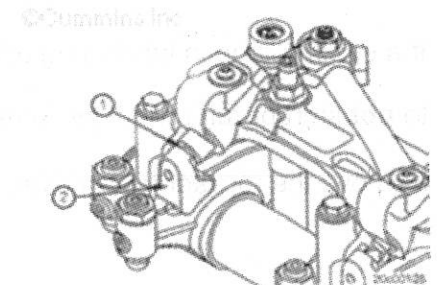

Engine features a 24V electrical system. Compressed brake is only applicable for 24V configuration.

### Initial Check

A stuck of oil flow solenoid valve can prevent the engine brake from starting or performing properly.

To check for a stuck solenoid valve, disconnect the electrical connection to the engine brakes and operate the engine again.

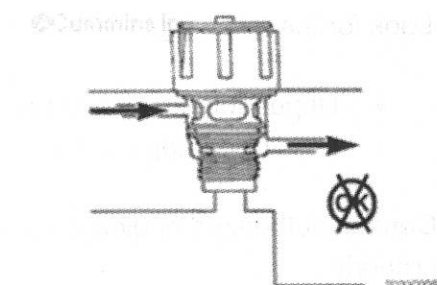

If exhaust gases can be heard escaping past the valves, the solenoid valve or valves **must** be replaced.

Contact an authorized engine brake dealer.

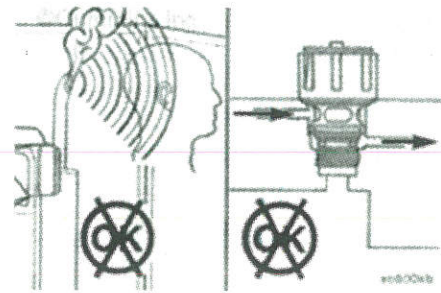
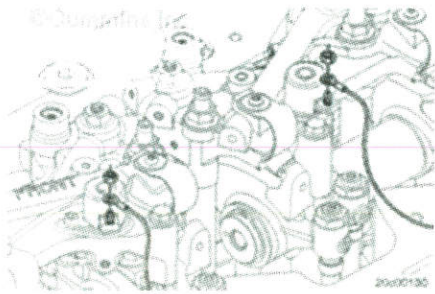

Improper adjustment or secondary piston damage will lead to engine rough running or failure of start.

To check the slave piston, remove the rocker lever cover.

Check slave piston clearance.

Measure and adjust clearance according to "Adjustment" section in this procedure.

Inspect the slave piston for damage.

If the slave piston is damaged, contact an authorized engine brake dealer for repair.

Install the Rocker Lever Cover.

If a sudden drop in lubricating oil pressure Cause the engine to **not** start or run rough, perform the following steps.

Remove the rocker lever cover.

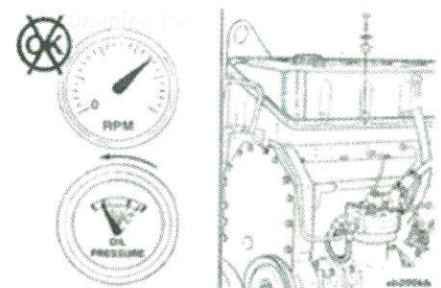
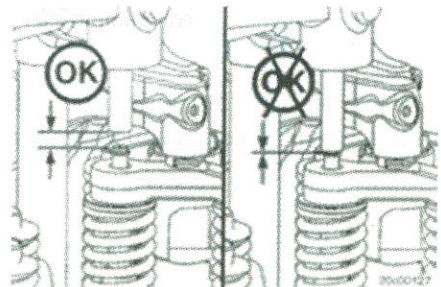
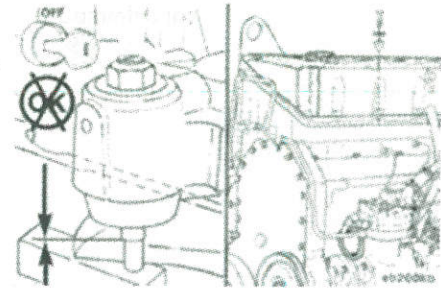

Look for the following:

- Upper solenoid valve seal ring missing or damaged
- Loss or damage of fuel supply pipe O-ring adaptor.

Contact authorized engine brake dealer to solve problems properly.

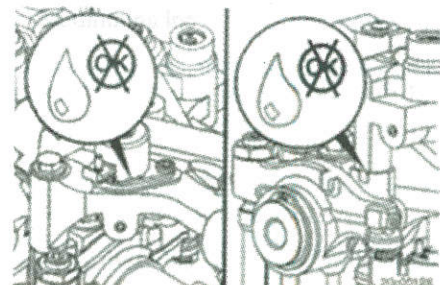

Install the Rocker Lever Cover.

If the engine is misfiring or has a loss of power:

- Remove rocker lever cover.

Measure and adjust clearance according to "Adjustment" section in this procedure.

Install the Rocker Lever Cover.

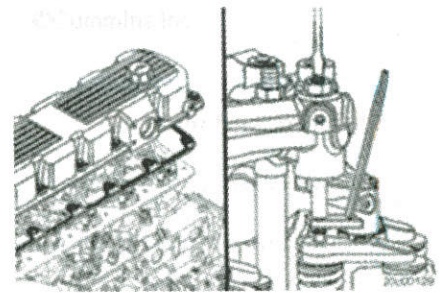

## REMOVE

Disconnect the connection between the terminal and solenoid supply & ground wire.

Remove the mounting bolts and its hex mounting nuts on the left side of engine brake.

Lift up engine brake housing from stud.

Remove assembly spacer from mounting studs.

Remove the mounting studs.

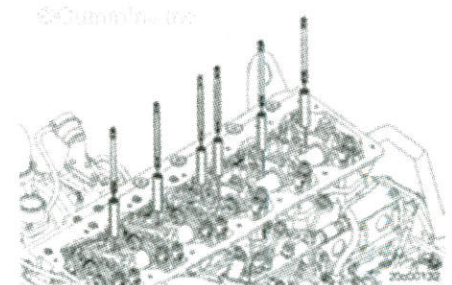
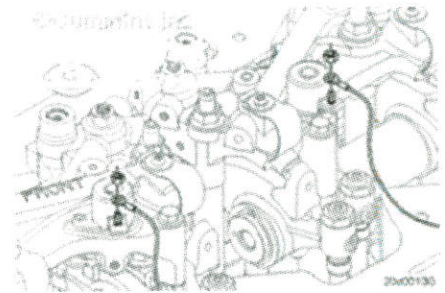
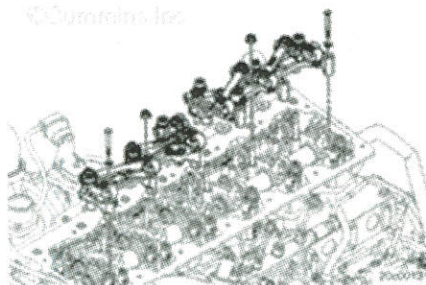

**NOTE:** If engine brake cannot be re-installed, remove fuel supply line adaptor and block the supply hole in the rocker pedestal .

Fix all the loosening cable in cable tray.

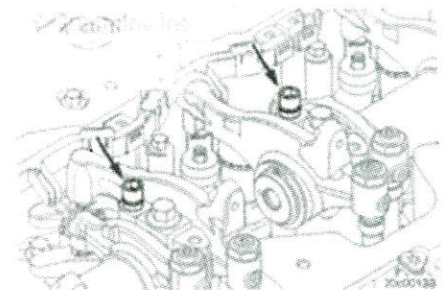

Claen and inspect for reuse



When using solvents, acids, or alkaline materials for cleaning, follow the manufacturer's recommendations for use. Wear goggles and protective clothing to reduce the possibility of personal injury.

Wear appropriate eye and face protection when using compressed air. Flying debris and dirt can cause personal injury.

Use an approved solvent to clean the brake housings. Dry using compressed air.

Inspect the housings for any missing or damaged parts.

Inspect the solenoid and terminals for damage.

Remove solenoid from housing, and check pin assembly for operation.

- Remove the inlet screen
- Press button with forefinger and press pin at the bottom with thumb to fix solenoid.
- Alternately push on the button and pin. Pin and button shall be moved freely.

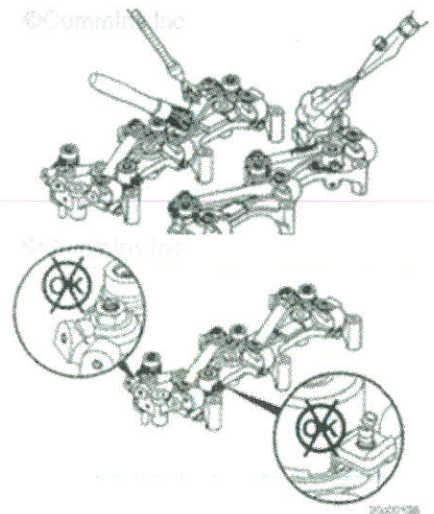

Check terminal resistance with ohmmeter.

- 24V non-return solenoid 32.6 - 39.8Ω
- Replace the solenoid if the resistance measured is **not** to specification.

Check that screen is **not** cracked or damaged. Check and confirm both sides of the terminal without abrasion. Before tightening the solenoid, confirm the solenoid has seated in the bore. Tighten solenoid hold-down bolts.

**Torque Value:** 10 N.m [89 in-lb]

Check and confirm the wiring connector is held on the studs. Tighten the fasteners.

**Torque Value:** 1.2 N.m [11 in-lb]

Check the solenoid sealing ring for abrasion or damage. If damaged, apply a thin oil on the new sealing ring, and replace with it.

If the solenoid is not within above specifications, it must be replaced. Contact authorized engine brake dealer to solve problems properly.

Apply a thin film of clean 15W-40 oil to the machined surfaces.

Check supply line O-ring adaptor for damage.

Check mounting stud and spacer for corrosion and other damage.

Check the main piston retaining spring for damage.

Check exhaust rocker arm brake gasket and observe them for loss or damage.

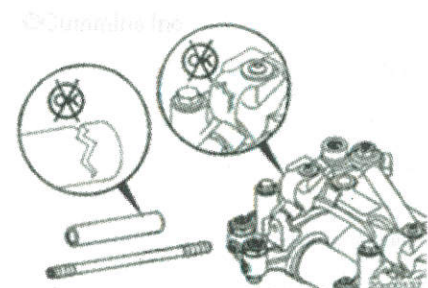
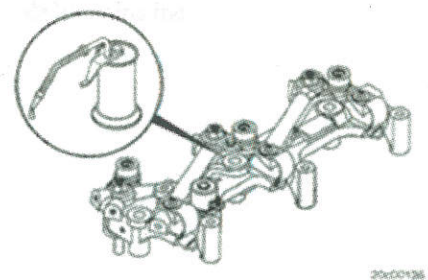

## Mount

Check that the correct wiring harness is installed. The engine may be equipped with the brake wiring or non-brake wiring.

If not used, install the correct harness.

Check and confirm installation of compressor brake jump pressing plate and confirm the actuator pin orientated to engine camshaft.

Oil supply connector shall installed inside the rocker pedestal. If the oil supply connector is not installed, execute the following operation:

- Remove every pedestal plug from oil supply hole
- Make sure the O-ring has no damage and is installed on the adaptor.

Install the oil supply connector into the rocker pedestal.

Install the six mounting studs into the cylinder head. Allen socket shall orientate upward.

Tighten studs manually until its bottom accesses threaded hole.

Install a mounting spacer on each studs.

Install the brake housing with "Front" mark to studs of cylinder No.1 to No.3.

Install the brake housing with "Rear" mark to studs of cylinder No.4 to No.6.

Install the mounting bolt and gasket into the rocker pedestal bracket through the left side of brake housing.

Install the mounting nuts onto the mounting studs.

Tighten all fasteners.

Tighten engine brake mounting bolts, every brakes according to the sequence shown in diagram from center to external.

**Torque Value:** 113 N.m [83 ft-lb]

Tighten engine brake mounting bolts, every brakes according to the sequence shown in diagram from center to external.

**Torque Value:** 33 N.m [24 ft-lb]

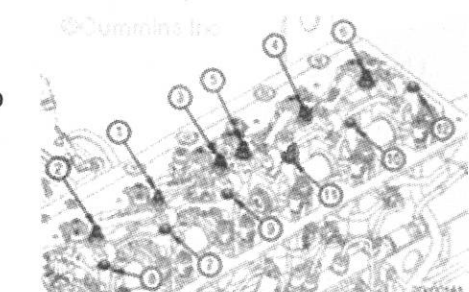
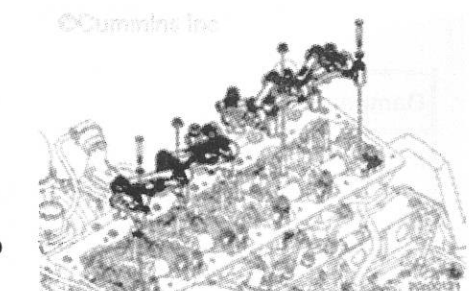
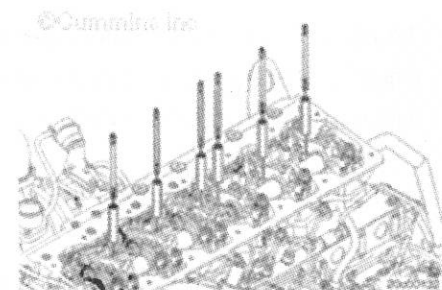
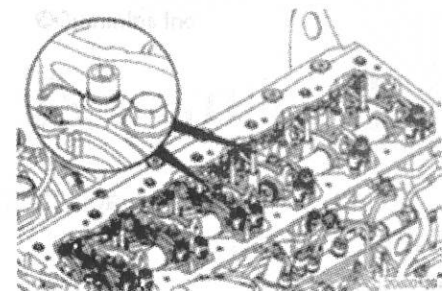
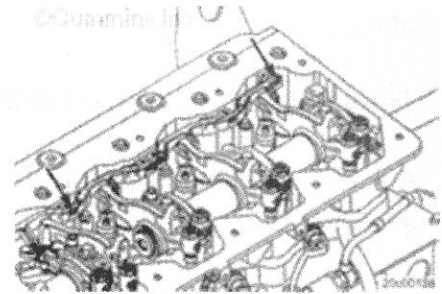

Connect solenoid valve power and ground wires and terminal, and tighten.

**Torque Value:** 1.1 N.m [10 in-lb]

Adjust the secondary piston clearance. See the Adjustment section in this procedure.

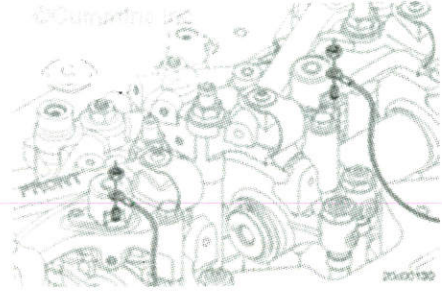

**Making Adjustments**

**⚠ CAUTION ⚠**

Do not overtighten the adjusting screws. Damage to the engine can occur.

Improper clearance will damage the engine.

To obtain maximum brake operating efficiency and prevent engine damage by piston-to-valve contact, complete the following instructions carefully.

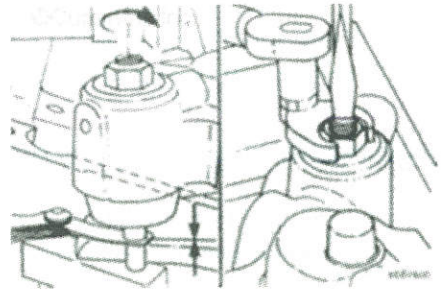

Adjust the exhaust valves on the appropriate cylinder.

After adjusting the exhaust valves on the appropriate cylinder, insert the correct feeler gauge.

Loosen locknut on slave piston adjusting screw.

Rotate engine to required position of the front engine vibration damper.

Damper position	Adjust the corresponding cylinders
A	1 and 6
B	2 and 5
C	3 and 4

Use DCEC® repair tool (part number 4919338) to adjust the brake lash of corresponding cylinders.

**Measurements**

	mm	inch
Engine brake slave piston clearance	3.2 ±0.051	0.118 ±0.002

Hold the adjusting screw in position and tighten the locknut.

Without torque wrench adapter

**Torque Value:** 34 N.m [25 ft-lb]

With torque wrench adapter, Part Number 3163196

**Torque Value:** 30 N.m [22 ft-lb]

After the slave piston adjusting screw locknut is tightened to the correct torque value, check the clearance with the feeler gauge again.

### Finishing Step

Install the Rocker Lever Cover.

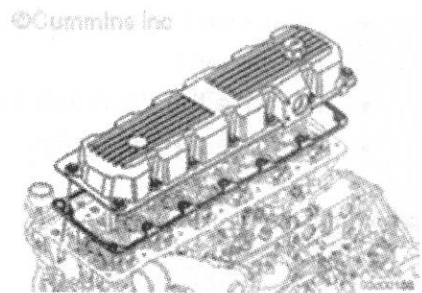

## 4: Maintenance content for every 800 hours or 8 months.

Overview: All maintenance checks and inspections listed in previous maintenance intervals **must** also be performed at this time, in addition to those listed under this maintenance interval.

### belt driven fan hub

#### Preparatory

- Remove the cooling fan. Refer to the OEM repair instructions.
- Remove the drive belt, cooling fan.
- Remove the fan pulley.

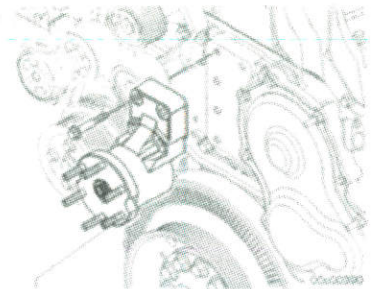

#### REMOVE

Remove the mounting capscrews and the fan hub assembly.

#### Claen and inspect for reuse

Inspect the fan hub for the following:

- Freedom of rotation
- Cracked
- Grease seal leakage.

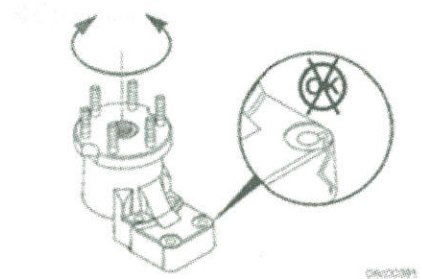

Repair or replace the fan hub if the fan hub does **not** rotate freely or if there is evidence of cracks or grease seal leakage.

If the fan hub is being replaced due to a bearing malfunction, inspect the uppermost idler pulley for a malfunction.

#### Mount

Make certain the correct fan center is used for the application.

Install the fan hub assembly and the capscrews.

Tighten the capscews.

**Torque Value:** 37 N.m [27 ft-lb]

#### Finishing Step

- Install fan hub pulley.
- Install the cooling fan drive belt.
- Install the cooling fan. Refer to the OEM repair instructions.

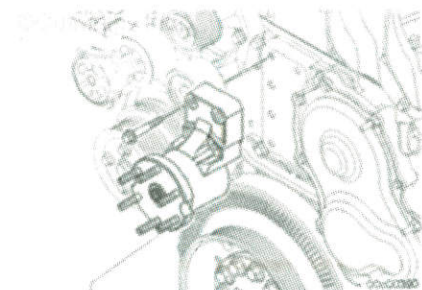

## Cooling fan belt tensioner

### Initial Check

Check the tensioner arm, pulley, and stops for cracks. If any cracks are observed, the tensioner **must** be replaced.

With the belt on, verify that neither tensioner arm stop is in contact with the spring casing stop. If either stop is touching, the drive belt **must** be replaced.

After replacing the belt, if the tensioner arm stops **are** still in contact with the spring casing stop, replace the tensioner.

Check the location of the drive belt on the belt tensioner pulley. The belt should be centered on, or close to the middle of the pulley. Unaligned belts, either too far forward or backward, can cause belt wear, belt roll-off, or increased, uneven tensioner bushing wear.

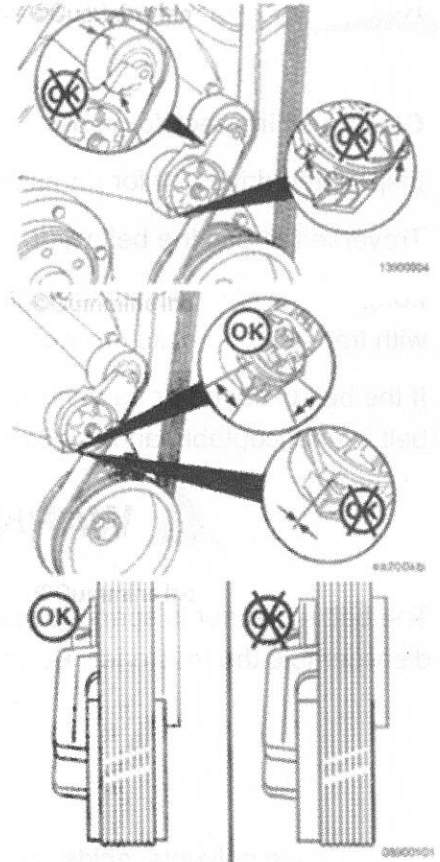

### Preparatory



Batteries can emit explosive gases. To reduce the possibility of personal injury, always ventilate the compartment before servicing the batteries. To reduce the possibility of arcing, remove the negative (-) battery cable first and attach the negative (-) battery cable last.

- Disconnect battery. Refer to the OEM repair instructions.
- Remove the drive belt, cooling fan.

### REMOVE

With the belt removed, verify that the tensioner arm stops are in contact with the spring casing stop. If they are **not** touching, the tensioner **must** be replaced.

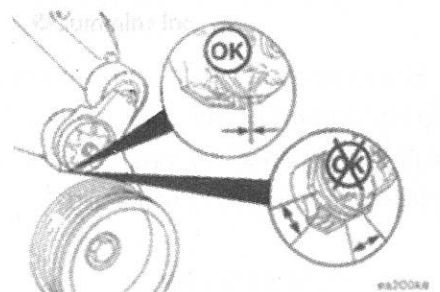

Remove the capscrew and belt tensioner from the bracket.

©Cummins Inc

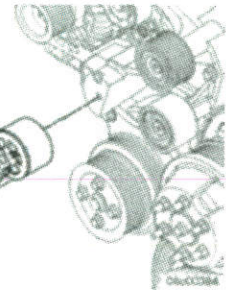

### Claen and inspect for reuse

Inspect the drive belt for damage.

Transverse (across the belt width) cracks are acceptable.

Longitudinal (direction of the belt length) cracks that intersect with transverse cracks are **not** acceptable.

If the belt is frayed or has any piece of material missing, the belt is unacceptable and needs to be replaced.

©Cummins Inc

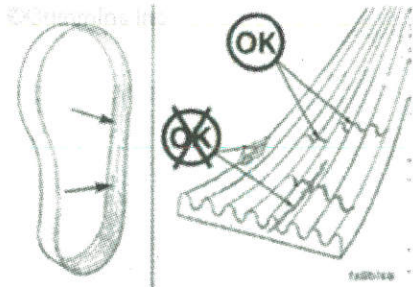

The belt tensioner is spring loaded. Do not attempt to disassemble the tensioner. Personal injury can result.



When using solvents, acids, or alkaline materials for cleaning, follow the manufacturer's recommendations for use. Wear goggles and protective clothing to reduce the possibility of personal injury.

Check the tensioner for dirt buildup. If dirt accumulates on belt tensioner, remove tensioner and clean it with solvent.

©Cummins Inc

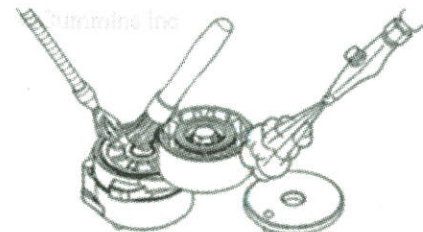

09c00125

Measure the clearance between the tensioner spring case and the tensioner arm to verify tensioner wear-out and uneven bearing wear. If the clearance exceeds 3 mm [0.12 in] at any point, the tensioner has failed and **must** be replaced as a complete assembly.

Experience has revealed that tensioners generally will show a larger clearance gap near the lower portion of the spring case, resulting in the upper portion rubbing against the tensioner arm. **ALWAYS** replace the belt when a tensioner is replaced.

©Cummins Inc

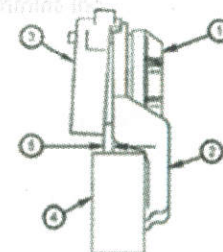

09c00025

1. Tensioner cap
2. Tensioner arm
3. Spring case
4. Tensioner pulley
5. Clearance gap.

Check the belt tensioner pulley and body for cracks. If cracks are found, replace the tensioner.

Inspect the tensioner for evidence of the tensioner arm contacting the tensioner cap. If there is evidence of these two areas contacting, the pivot tube bushing is worn and the tensioner **must** be replaced.

Spin the belt tensioner pulley. The pulley **must** spin freely. If pulley **cannot** rotate freely, replace belt tensioner.

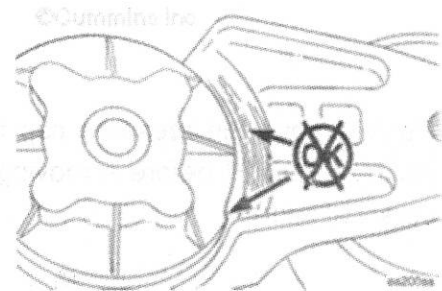
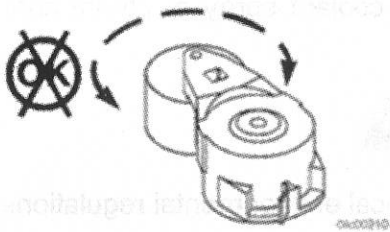
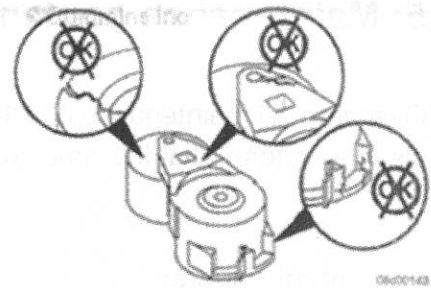

## Mount

Align the dowel on the tensioner with alignment hole in the mounting bracket.

Install belt tensioner and mounting capscrew.

Tighten the capscrews.

**Torque Value:** 50 N.m [37 ft-lb]

After checking the torque, use a breaker bar with a 1/2-inch ratchet to rotate the tensioner slowly away from the area of belt contact (clockwise and down).

If the arm rotates away with any roughness or hesitation, replace the tensioner.

## Finishing Step

- Connect the battery. Refer to the OEM repair instructions.
- Install the cooling fan drive belt.
- Operate the engine and check for proper operation.

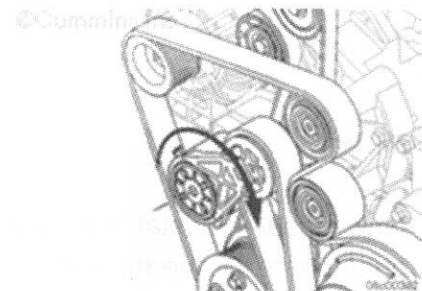
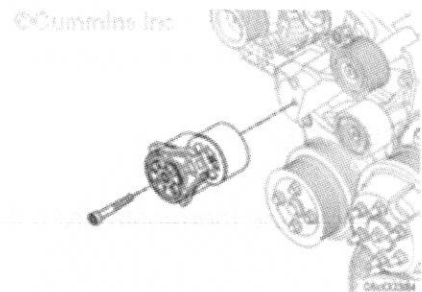

## 5: Maintenance content for every 1,200 hours or 12 months

Overview: All maintenance checks and inspections listed in previous maintenance intervals **must** also be performed at this time, in addition to those listed under this maintenance interval.

### Coolant thermostat

#### Preparatory



Don't remove the pressure cap from a hot engine. Wait until the coolant temperature is below 50°C [120°F] before removing the pressure cap. Heated coolant spray or steam can cause personal injury.



Coolant is toxic. If not reused, dispose of in accordance with local environmental regulations.

- Drain cooling system.
- Remove the upper radiator hose. Refer to the OEM repair instructions.
- Remove the coolant thermostat housing.

#### REMOVE

Remove the thermostat from the thermostat housing.

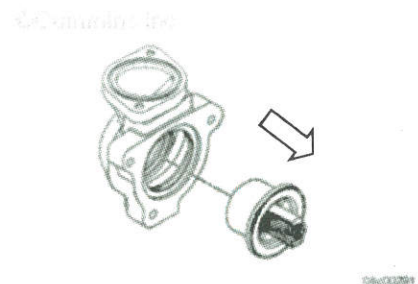

#### Mount

Install the thermostat in the thermostat bore by pushing on the outer rim of the thermostat.

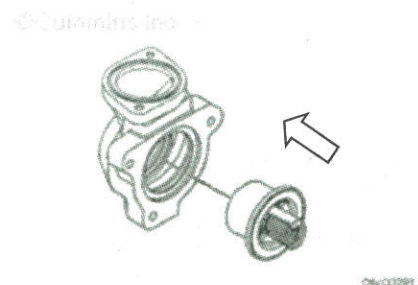

#### Finishing Step

- Fill the cooling system.
- Operate the engine until the coolant reaches a temperature of 70°C [160°F] and check for coolant leaks.

## 6: Maintenance content for every 2,000 hours or 20 months

Overview: All maintenance checks and inspections listed in previous maintenance intervals **must** also be performed at this time, in addition to those listed under this maintenance interval.

### Engine Steam Clean - Clean



When using a steam cleaner, wear protective clothing, safety glasses as well as face shield. Hot steam can cause serious personal injury.

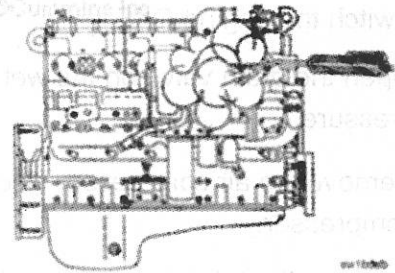

Steam is the best method of cleaning a dirty engine or a piece of equipment. If steam is **not** available, use a solvent to wash the engine.

Protect all electrical components, openings, and wiring from the full force of the cleaner spray nozzle.

### Radiator hose

#### Maintenance Check.

Check all hoses for cracks, cuts, or collapsing.

**Note:** Silicone engine coolant hose will exhibit swelling due to hose elasticity.

If damage is found, replace the hoses.

Contact a DCEC Authorized Repair Location.

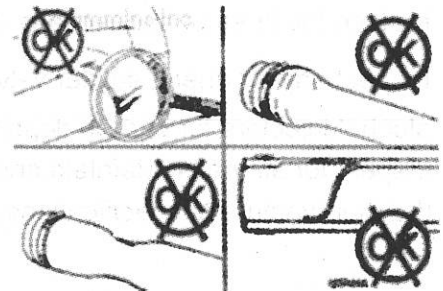

### Air compressor discharge line (if equipped)

#### Overview

All air compressors have a small amount of oil carryover which lubricates the piston rings and moving parts. When this oil is exposed to normal air compressor operating temperatures over a period of time, it will form varnish or carbon deposits. If the following maintenance check are not performed, the air compressor piston rings will wear and not seal correctly.

## Maintenance Check

# ▲ WARNING ▲

Wear appropriate eye and face protection when using compressed air. Flying debris and dirt can cause personal injury.

Switch the engine OFF.

Open the drain valve on the wet tank to release the system air pressure.

Remove the air compressor discharge line from the air compressor.

Measure the total carbon deposit thickness inside the air discharge line as shown. If the total carbon deposit ( $X + X$ ) exceeds 2 mm [1/16 in], clean and inspect the cylinder head, the valve assembly, and the discharge line. Replace as necessary.

Contact the DCEC Authorized Repair Location for procedures.

If the total carbon deposit exceeds specifications, continue checking the air discharge line connections up to the first tank until total carbon deposit is less than 2 mm [1/16 in]. Clean or replace the lines or connections that exceed the specification.

Inspect any air driers, splitter valves, pressure relief valves, and alcohol injectors for carbon deposits or malfunctioning parts.

Inspect for air leaks. Maintain and repair the parts according to the manufacturer's specifications.

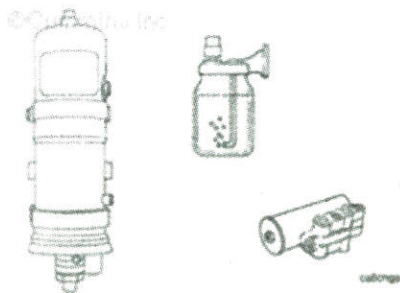
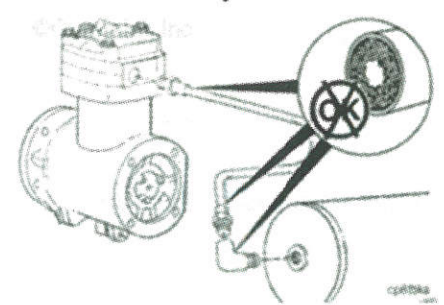
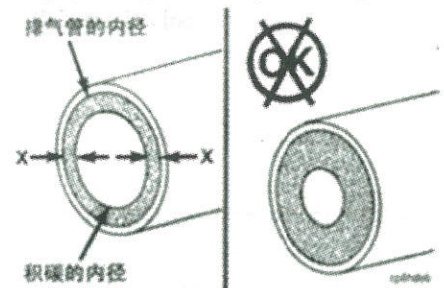
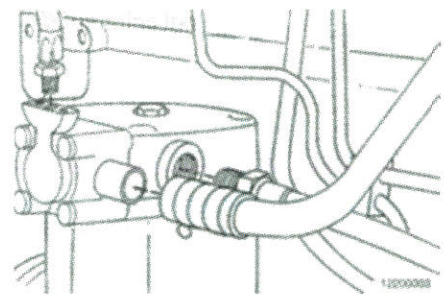
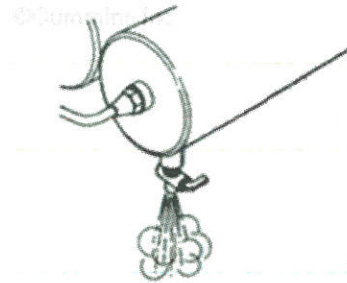

## Viscous Damper

### INSPECTION

The silicone fluid in the vibration damper will become solid after extended service and will make the damper inoperative. An inoperative vibration damper can cause major engine or drivetrain malfunction.

Check the vibration damper for evidence of fluid loss, dents, and wobble.

Inspect the vibration damper thickness for any deformation or raising of the damper cover plate.

If any of these conditions are identified, contact your local Cummins Authorized Repair Location to replace the vibration damper.

For vibration damper location, refer to "Engine Diagrams" in "Engine Identification".

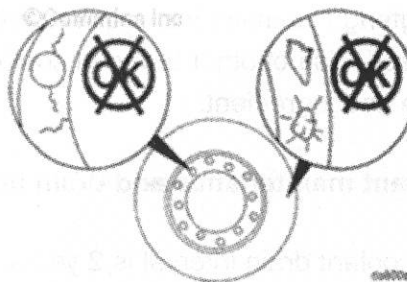

## 7: Drain the antifreeze coolant every 2,400 hours or 24 months

### Coolant Selection



Coolant is also called antifreeze or antifreeze antirust liquid.

Dongfeng Cummins Inc. requires only genuine Dongfeng Cummins long life organic coolant can be used. Use of other brand of coolant may cause unexpected adverse reaction due to coolant PH value and ingredient.

### Coolant maintenance and drain interval

The coolant drain interval is 2 years or 2,400 hours, and can be filled at actual.

Drain the coolant that meets the technical requirements.

**WARNING**

Do not remove the pressure cap of radiator from a hot engine. Wait until the coolant temperature is below 50°C [120°F] before removing the pressure cap. Heated coolant spray or steam can cause personal injury.

★Do not add cold coolant to a hot engine. Engine castings can be damaged. Allow engine to cool to below 50°C [120°F] before adding coolant.

★Never use a sealing additive to stop leaks in the coolant system. This can result in cooling system plugging and inadequate coolant flow, causing the engine to overheat.

### 1, Coolant drains

★Remove the pressure cap. Drain the cooling system by opening the drain valve on the radiator and opening the drain valve on the bottom of the engine oil cooler housing. After the cooling system is completely drained, close the drain valves.

★Check for damaged hoses and loose or damaged hose clamps. Replace as necessary.

★Check the radiator for leaks, damage, and buildup of dirt. Clean and replace as required.

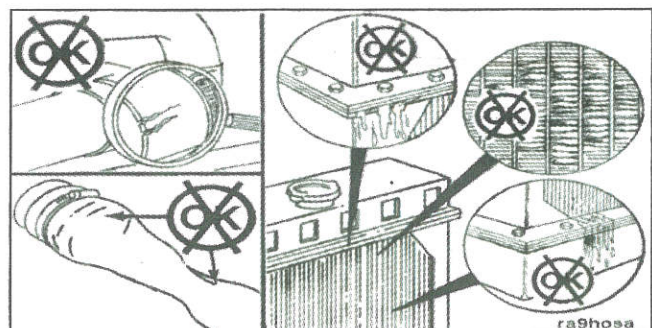
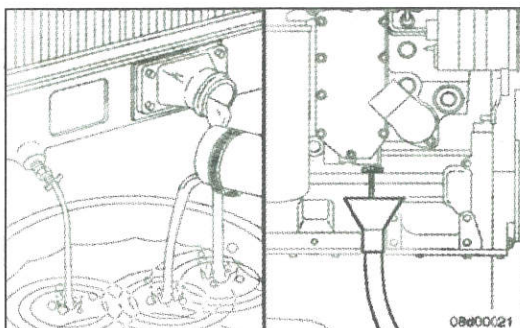

## 2. Cooling system flush (if necessary)

★ Fill the cooling system with a certain amount of Fleetguard® Restore™, Restore Plus™ or equivalent detergent.

★ Fill the system with plain water. Turn all cab heater switches to HIGH in order to allow maximum coolant flow through the heater core(s). **The blower does not** have to be on.

★ AT NORMAL OPERATING TEMPERATURES, AT LEAST 85°C [185°F], OPERATE THE ENGINE AT HIGH IDLE FOR FIVE MINUTES WITH THE COOLANT TEMPERATURE ABOVE 85°C [5°F]. Shut off the engine, allow to cool to 50°C [122°F], and drain the cooling system. Flush again if water being drained is still dirty.

## 3. Coolant filling

### ⚠ CAUTION ⚠

The system must be filled properly to prevent air locks. During filling, air must be vented from the coolant passages. Be sure to open the petcock on the aftercooler for aftercooled engines. Wait 2 to 3 minutes to allow the air to be vented; then add the mixture to bring the coolant level to the top.

### ⚠ CAUTION ⚠

During all coolant fill procedures, all coolant flow valves to equipment heating systems must be opened in order to purge air from those systems as well as from the base engine cooling system. These valve must remain open during the engine cooling system de-aeration process. Make sure adequate coolant levels are maintained in the coolant reservoir during the entire fill procedure. **SPECIAL CARE MUST BE TAKEN WHEN FILLING ENGINE EQUIPPED WITH EGR COOLER TO MAKE SURE ALL AIR IS PURGED FROM THE SYSTEM.**

★ After finishing the coolant filling, please operate the engine at idle for 25 minutes to completely drain out the air in cooling system. Turn all cab heater switches to HIGH in order to allow maximum coolant flow through the heater core(s).

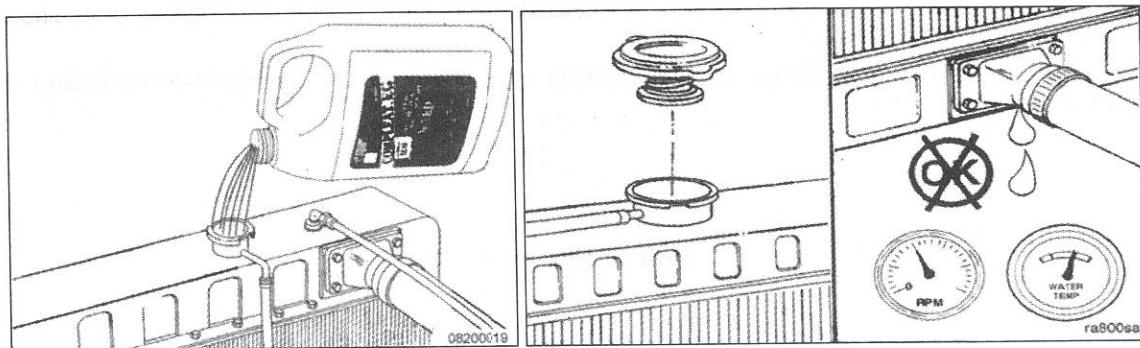

★ Within 2 or 3 days after new coolant, pay attention to inspect the coolant level, and supplement coolant at actual to prevent the coolant deficiency after air is purged from the cooling system.

# Maintenance Assistance Guide

## Normal conditions

Personnel at Dongfeng Cummins Authorized Repair Locations can help you operate and maintain your engine. We have a nationwide Maintenance Network consisting of more than 400 Dongfeng Cummins Authorized Services, whom are trained, and can provide you the first-class advice, specific maintenance and complete parts support. Refer to the yellow pages on the phone book or this chapter content to find the nearest Dongfeng Cummins Authorized Service.

## EMERGENCY

Dongfeng Cummins Engine Company, Ltd. Marketing Company provides a 24-hour, toll free telephone number to aid in technical and emergency service when a Cummins Authorized Repair Location cannot be reached.

24-hour service hotline:

0710 – 3320168 or 400 880 9119

## Problem Solving

Usually, problems caused by sale, maintenance or repair can be solved by the local Dongfeng Cummins Authorized Service. Refer to the yellow pages on the phone book to find the nearest Dongfeng Cummins Authorized Service.

If the problem cannot be solved satisfactory, please follow the steps listed below.

1. If you have a disagreement with the repair location, please contact Dongfeng Cummins dealer, since they have an agreement with the repair location
2. If you have a disagreement with the dealer, please contact the nearest Dongfeng Cummins Oversea Service personnel; nevertheless, most problems can be resolved. Before contact, please record the following information:
  - a. Engine model and serial number
  - b. Equipment composition types
  - c. Total kilometers [miles] or hours of operation
  - d. Warranty start date
  - e. Nature of problem
  - f. Current problem summary in order of occurrence
  - g. Name and location of the Cummins Dealer or Distributor
3. If you still cannot get a satisfactory solution by Dongfeng Cummins Service or Dongfeng Cummins Oversea Service personnel, please write to:  
Dongfeng Cummins Engine Company, Ltd. Marketing Company or dial 24-hour service hotline : 0710 – 3320168 or 400 880 9119.

**End of this manual!**

**Dongfeng Cummins Engine Co., Ltd.**  
**reserves the right of final explanations**

Add: High & New Technology Industry Development  
Zone, Xiangyang City, Hubei Province, China  
Service hot line: 400-880-9119  
Web Site: [www.dcec.com.cn](http://www.dcec.com.cn)  
Postcode: 441004  
Fax: 0710-3320886  
24 Hours Service Hot Line: 0710-3320168