

QDF MODEL

● DRAWING

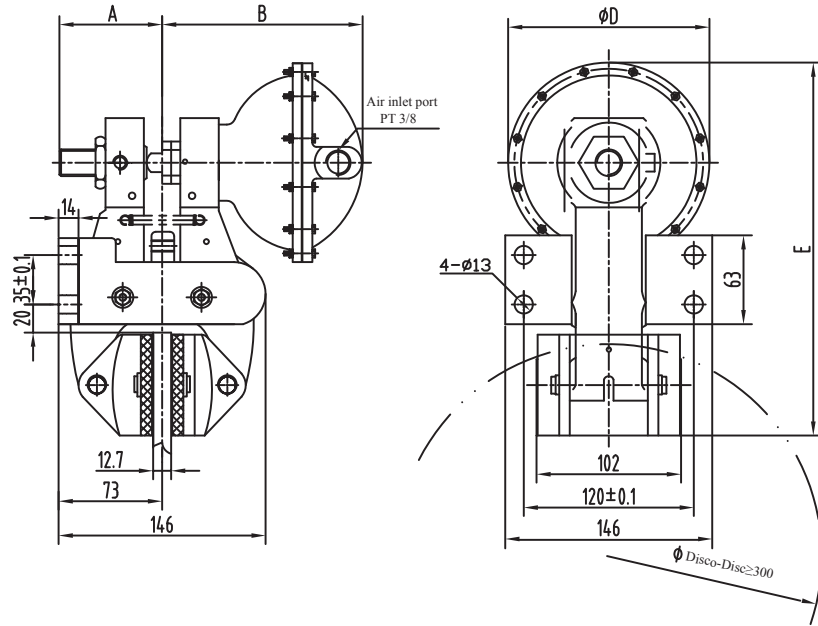

■ SPECIFICATION

Model	Main dimension(mm)					Volume of Air (cm ³)	Weight (kg)
	A	B	C	φD	E		
QDF-2	72.5	141.5	PT3/8	142	264.5	0.2	10.3
QDF-3	72.5	160	PT3/8	184	285.5	0.4	11.5

■ AIR PRESSURE VERSUS TORQUE

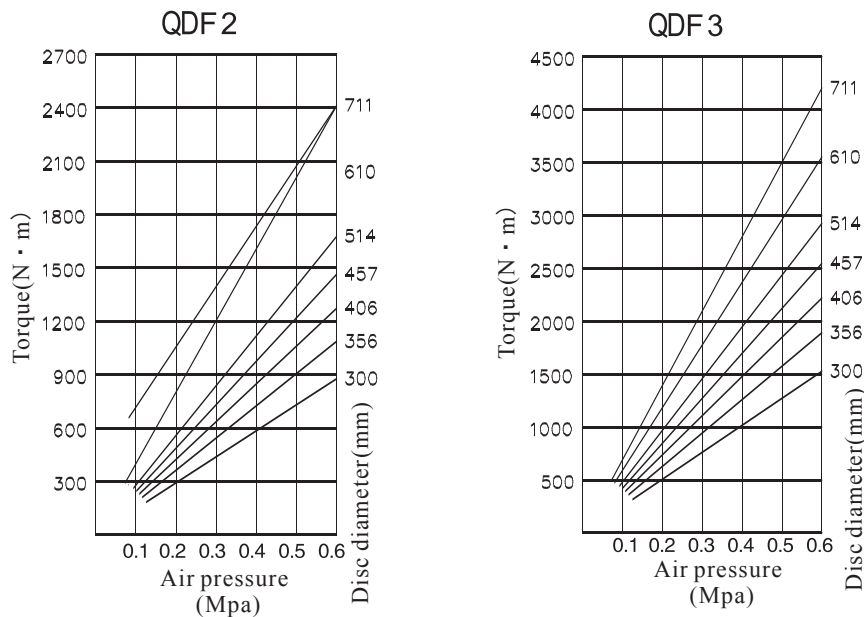

Remark:

1. One couple of friction discs max total abrasion: 12mm
2. New friction disc thickness: 11mm
3. When air pressure is 6 bar, total clamp force of brake clamp:

QDF-2: 7500N

QDF-3: 12700N